



**GLOBE
CONTROL VALVE**

GLS[®]



INTRODUCTION

The GL $\bar{5}$ globe control valve presents a superior performance, while providing an easy, quick and economical maintenance. Differently from other control valves operated by spring-diaphragm actuators, the GL $\bar{5}$ Series operated by double acting spring-cylinder actuator takes advantage of its high pneumatic stiffness, which ensures an excellent and accurate positioning in throttling control, as well as fast and reliable response to the control signal. Since the actuator operates with air supply pressure up to 150 psi (10.3 Bar), the GL $\bar{5}$ Series provides also enough power to ensure the specified shutoff class, even under high differential pressures.

While the spring-diaphragm actuators depends entirely on the spring force to close the valve, in the GL $\bar{5}$ Series control valves, the spring force, the air supply pressure and the pressure of the process fluid itself are combined together to produce a high closing force, thus assuring high levels of tightness. Due to its self-centering seat design, the GL $\bar{5}$ Series valve easily meets the tightness levels specified.

The most common problems associated to control valves may be attributed to the cage-guided systems. The close contact between the metallic surfaces of the seat retainer (cage) and the plug frequently results in friction wear and jamming. For this reason, the GL $\bar{5}$ Series has a double upper guide system, which is located outside the flow path and completely eliminates direct contact between the plug and the seat retainer.

Same as the valve, the actuator also has a light, compact construction, and permits easy handling when compared with conventional spring-diaphragm actuators.

Due to its advanced design, the assembly comprised by the valve and the actuator presents a high level of sturdiness and performance, making the GL $\bar{5}$ Series a worldwide reference in its category.

GL $\bar{5}$ SERIES – BODY SUB-ASSEMBLY (FIGURE 1)

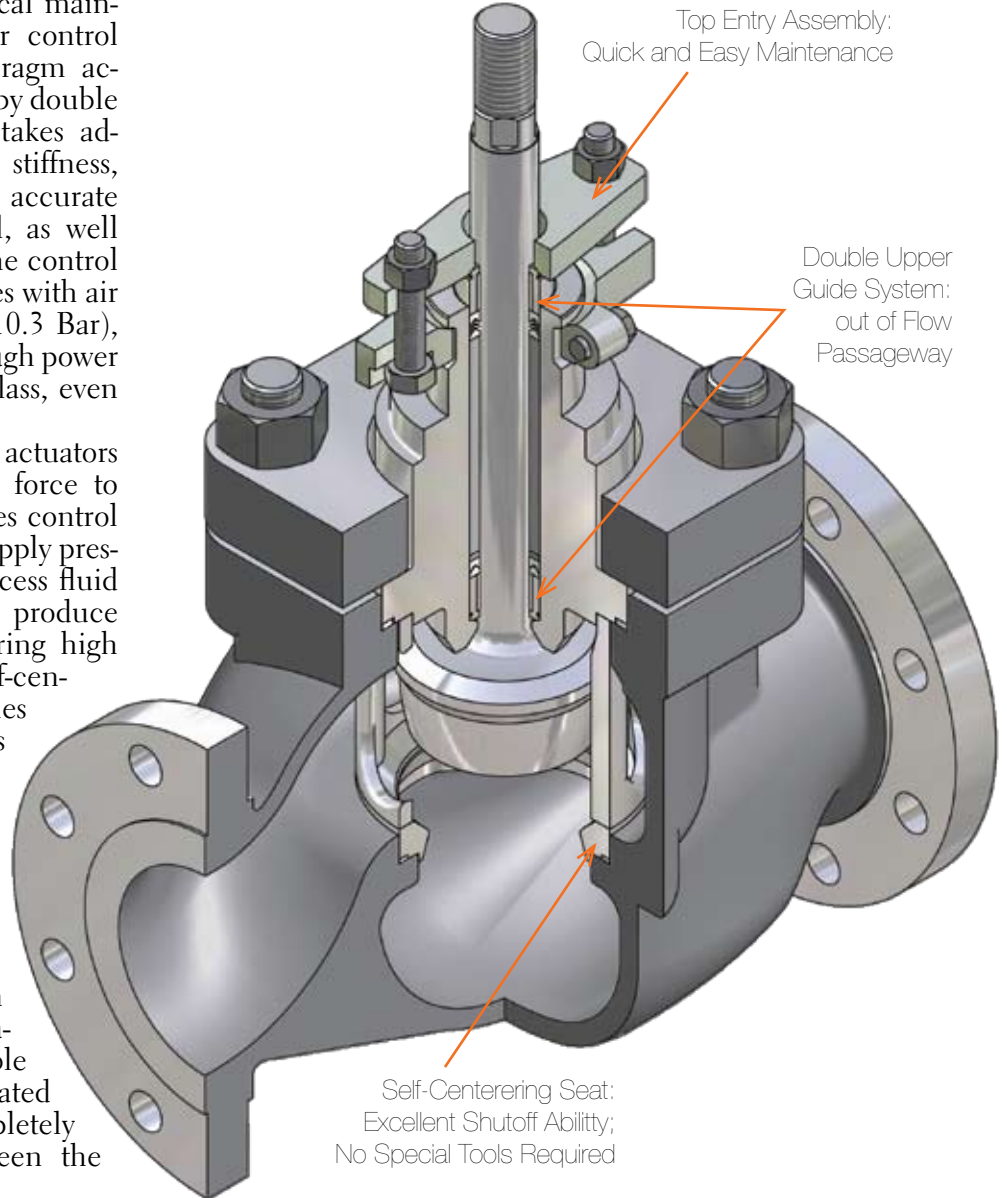

Rangeability 30:1 (Typical)

ANSI Class IV Shutoff – Metal Seat *

ANSI Class VI Shutoff – Soft Seat *

* Standard for valves with unbalanced trim.

Conventional Globe-style Body

The GL $\bar{5}$ Series globe-style bodies (fig.1) present a streamlined and smooth passageway. The internal passages of the body presents a nearly constant area with no pockets, allowing a high capacity with minimum turbulence.

These bodies are designed with more uniform wall thickness, resulting in lower weight and lower cost, specially when the body is manufactured in stainless steel or in more expensive alloys.

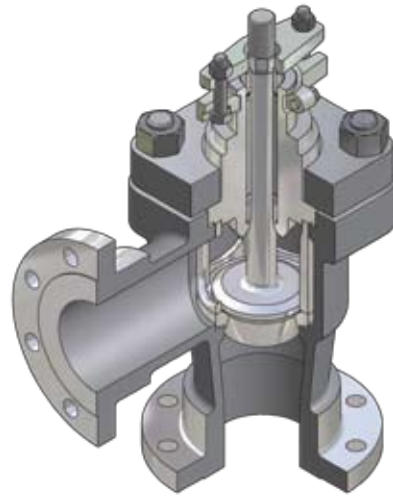

ANGLE-STYLE BODY (FIGURE 2)

Angle-style Body

The GL $\bar{5}$ valve with angle body is fully interchangeable with the globe-style valve: except for the body, all other components are the same.

Depending on the application for which the valve is intended, the GL $\bar{5}$ valve with angle body may be supplied with an optional venturi-type seat ring, which extends itself up to the outlet flange of the body and provides an additional protection against the erosive action of the fluid.

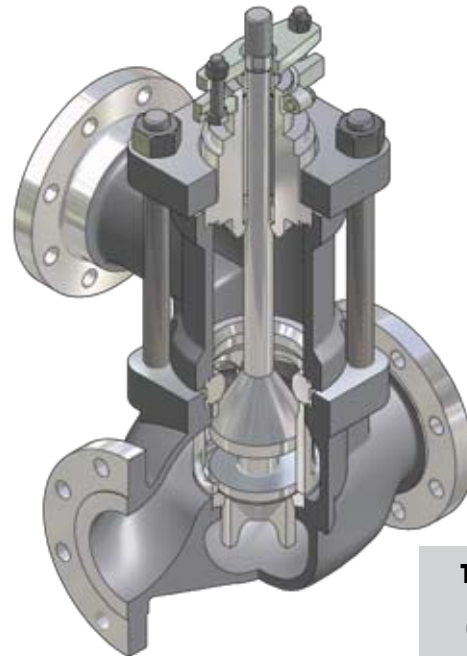

THREE-WAY BODY (FIGURE 3)

Three-way Body

Three-way bodies are used in applications with converging flow (mixing action) or diverging flow (bypass action). Due to the high degree of components interchangeability of the GL $\bar{5}$ valve design, a standard globe valve can be easily converted into a three-way valve with the simple addition of a three-way adapter, one upper seat, two gaskets and a special plug suitable for three-way valves.

Body with Steam Jacket

The GL $\bar{5}$ Series with steam jacket uses a globe-style body equipped with oversized blind flanges for full jacket or standard flanges for a partial jacket. Usually the jacket is designed to operate with saturated steam at 150 psig (10.3 Bar) and it is equipped with NPT threaded connections (other connections are available upon request). When ordering a control valve equipped with steam jacket, the user shall specify the jacket type desired, as well the steam quality, the number and type of connections needed.

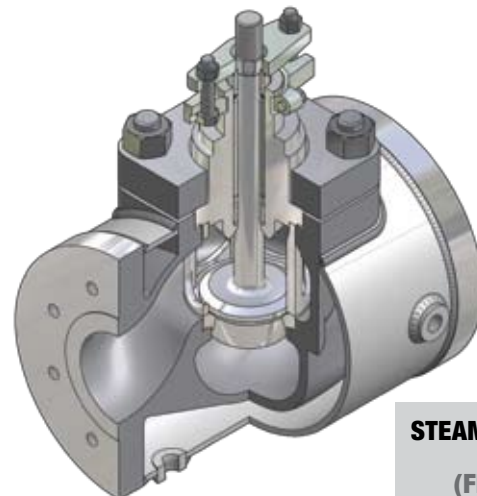

STEAM JACKETED BODY (FIGURE 4)

In modern process control, when thinking of sturdiness, versatility and performance, the GL \bar{S} Series is the common denominator:

Rugged

The GL \bar{S} valve construction makes it less prone to corrosion attacks from process fluids when compared to conventional globe valves.

The rugged plug stem, as well as other valve components, is designed for heavy-duty services and can withstand high differential pressures.

Valves equipped with separable flanges (up to 3 inches) comply with all applications range covered by ANSI Class 600 by means of a simple change of the process connection flanges.

When necessary, optional low noise and anti-cavitation trim are also available.

Seating

Besides providing an accurate control, the concept of the GL \bar{S} valve with a single and self-centering seat also provides an exceptional shutoff capacity, normally assisted by the fluid pressure. In normal conditions, with the air supply, the double acting spring-cylinder actuator assures a high seating force; in case of air supply loss, the actuator spring plus the resulting force from fluid pressure, move the plug to required failsafe position.

Easy, quick and low-cost maintenance

Top entry assembly simplifies maintenance tasks. Once the bonnet flange nuts are removed, the bonnet and the plug may be removed from the valve, allowing the access to the other internal components.

The clamped-in seat ring, secured by the seat retainer, as well as all other components of the valve and the actuator, do not require the use of special tools for its disassembly and reassembly.

The compact size of the valve and its low weight helps its handling for maintenance and for installation in the process.

Guiding and Packing

The GL \bar{S} Series guiding system deserves a special comment. Besides eliminating the disadvantages of the guiding system at the seat retainer, the GL \bar{S} guides, well spaced and with large bearing support surfaces, eliminate the problems related to vibration in control valves.

Due to the use of this advanced guiding system, the rugged plug stem of the GL \bar{S} valve may be subjected to twice the thrust produced by available oversized actuators, without buckling risks.

The large depth of the GL \bar{S} Series packing box allows the use of all packing options offered by Valtek Sulamericana, and the excellent surface finish of the bonnet bore and the plug stem contributes for a long packing life, with no leakage.

Trim that do not jam

The double upper guide system, located out of the flow path, assures a perfect alignment of the plug stem, while providing considerable clearance between the plug head and the seat retainer, eliminating friction problems related to the guiding system in the seat retainer (cage-guided).

Versatile

In addition to the conventional globe-style bodies, angle-style, three-ways or steam-jacketed bodies are also available; these bodies are compliant with several standards concerning face-to-face dimensions.

The modular concept of design assures an interchangeability degree between the different versions and sizes that is the highest degree among the valves available in the market, consequently reducing the need of spare parts.

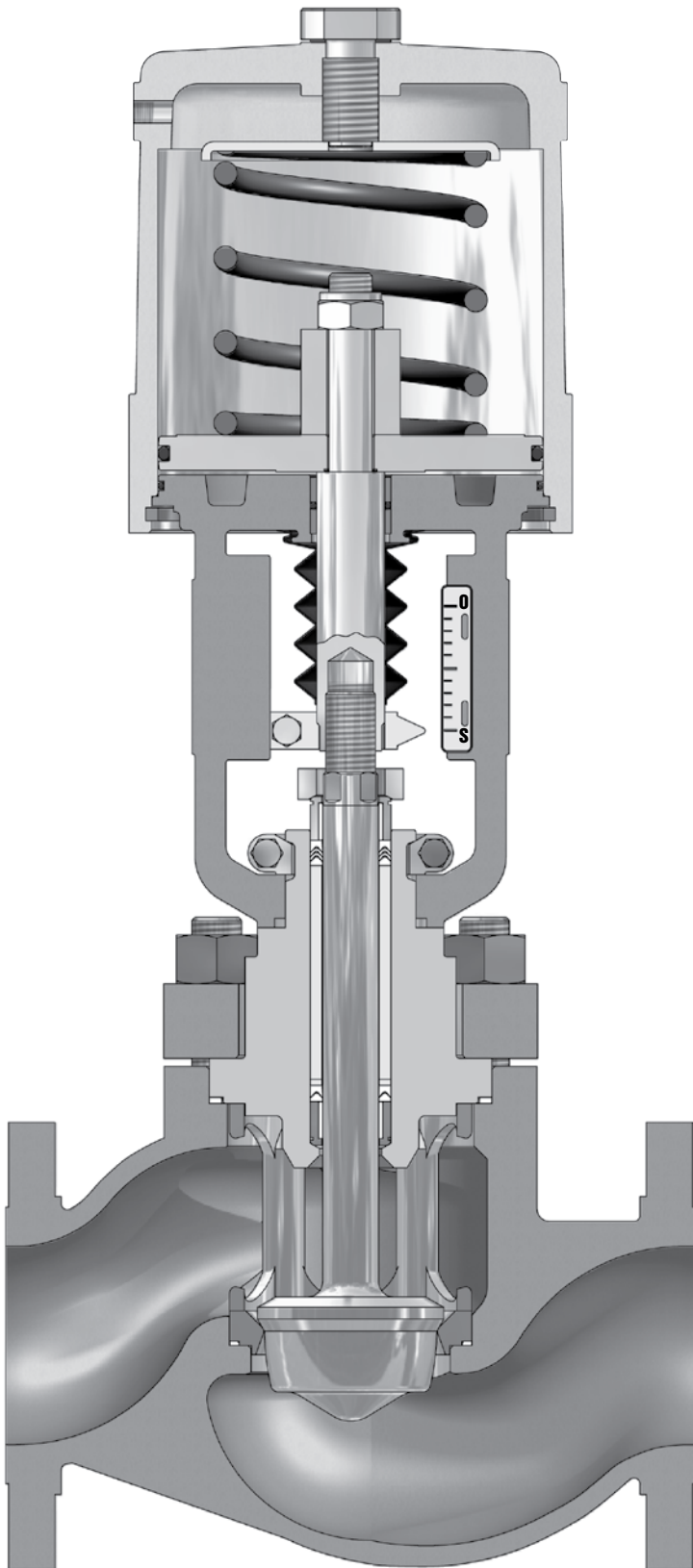

GL5 CONTROL VALVE (FIGURE 5)

Double acting spring-cylinder actuator – Advantages:

- »» Presents high actuating thrust and pneumatic stiffness;
- »» Field reversible, without the need of additional parts;
- »» Provides reliable operation;
- »» More compact than spring-diaphragm actuators with equivalent thrust;
- »» Operates with a controlled movement and high speed stroke;
- »» Ensures an accurate positioning, with high response capacity;
- »» High repeatability;
- »» Allows the assembly of several types of positioners and accessories;
- »» Optionally can be supplied with different types of manual handwheels and stroke stops;
- »» Operates with air supply pressure up to 150 psi (10.3 Bar), with no need of a pressure regulator.

The GL5 Series valve bodies have raised face surfaces, either in valves equipped with separable flanges or in valves supplied with integral flanges. In order to have a better sealing to the adjacent piping flanges, the contact surfaces of valve flanges are machined with spiral grooves. Other optional flange facing are available, such as: smooth finish, flat face, RTJ, large and small tongue and, large and small groove.

Separable Flanges

The connection to the process through separable flanges is standard for valves up to 4 inches in ANSI Class 150, 300 and 600. Using separable flanges, an ANSI Class 600 body can be easily adapted to operate in ANSI Class 150, 300 or 600 services by means of a simple change of end flanges.

Separable flanges are generally supplied in carbon steel, in order to get a higher cost reduction, although stainless steel flanges may be specified to meet special requirements of operating temperature and/or corrosive environments.

Bonnet Flange

The bonnet flange design uses the same concept of the separable end flanges of the GL5 valve body. Usually the bonnet flange is made from carbon steel, but it may be manufactured in stainless steel when necessary.

Bonnet Flange Bolting

The GL5 Series bonnet is attached to the valve body by means of studs and nuts. The standard material is ASTM A193 Gr. B7 for studs and ASTM A194 Gr. 2H for nuts, suitable for operating temperatures from -20 to 800°F (-28 to 426°C).

Optionally, studs and nuts may be supplied also in stainless steel, complying with a temperature range from -425 to 1500°F (-253 to 815°C). These temperature limits are valid for maximum operating pressure established by the last edition of ANSI B16.34.

SEPARABLE FLANGE (FIGURE 6)

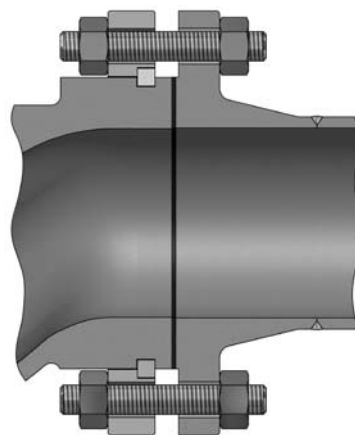

INTEGRAL FLANGE (FIGURE 7)

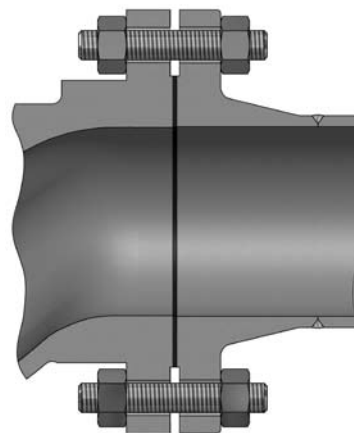

SEPARABLE END AND BONNET FLANGES (FIGURE 8)

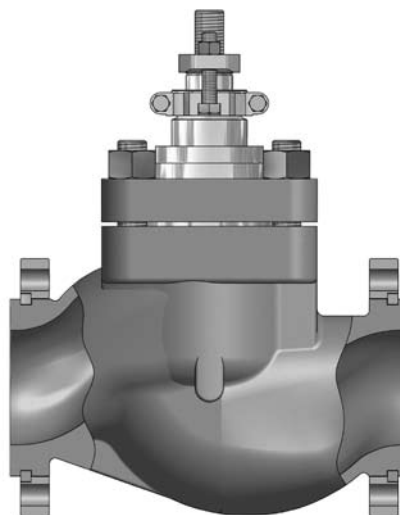

END CONNECTIONS (TABLE I)

TYPE OF END CONNECTION	VALVE SIZE (INCHES)	ANSI CLASS	STANDARD FACE-TO-FACE (ANSI/ISA)
Separable Flanges	0.5 to 4	150-600	75.08.07
Integral Flanges	0.5 to 48	150-600	75.08.01 ⁽¹⁾
NPT Threaded	0.5 to 2	150-600	75.08.03 ⁽²⁾
Socketweld (SW)	0.5 to 4	150-600	75.08.03 ⁽²⁾
Buttweld (BW)	0.5 to 36	150-600	75.08.05 ⁽²⁾⁽³⁾

⁽¹⁾ Valves larger than 16 inches have face-to-face dimensions according to Valtek Sulamericana's Standards.

⁽²⁾ Long pattern.

⁽³⁾ Valves larger than 18 inches have face-to-face dimensions according to Valtek Sulamericana's Standards.

GASKETS, CLAMPS

Gaskets

The GL \bar{S} Series is designed with the bonnet gasket totally enclosed. The GL \bar{S} valve bonnet has a shoulder projection that actuates as a mechanical stop, which limits the gasket compression. Thus, the bonnet gasket remains completely sealed and its compression is determined by the depth of the shoulder projection existing in the bonnet. Body, seat retainer and the seat itself are machined within tight tolerances to assure the proper gasket compression. Differently from the bonnet, the seat does not touch directly the body (metal to metal), maintaining the proper clearance to compensate the mechanical tolerances and thermal expansion.

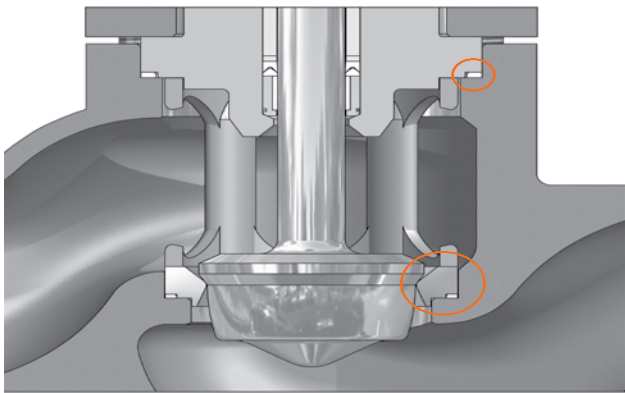

BODY GASKETS (FIGURE 9)

Clamps

The GL \bar{S} Series actuator is usually attached to the valve body by means of two yoke clamps, manufactured with investment cast stainless steel. Each clamp has a flat-sloped surface so, when one clamp is bolted to the other, a force is generated, securing the actuator yoke firmly to the valve bonnet. Differently from the conventional threaded clamps, the design of GL \bar{S} clamps allows its easy removal, even under severe corrosion conditions.

For those valves with larger sizes or higher pressure classes, the actuator yoke may be bolted directly to the valve bonnet.

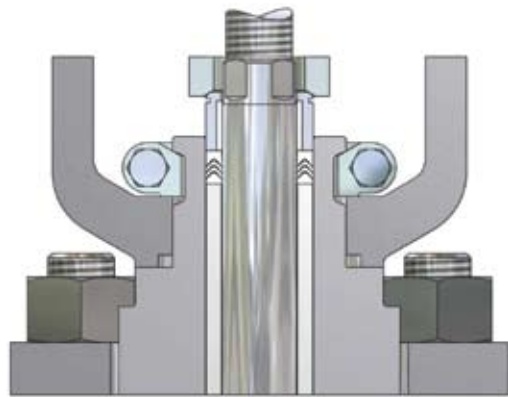

YOKE CLAMP (FIGURE 10)

TEMPERATURE AND PRESSURE LIMITS FOR VALVE GASKETS (TABLE II)

	TYPE	GASKET MATERIAL	TEMPERATURE LIMITS		PRESSURE LIMITS
			°F	°C	
Standard Gaskets	Flat	PTFE	-200 to 350	-130 to 177	6000 psi @ -200°F (415 Bar @ -130°C) / 1000 psi @ 350°F (69 Bar @ 177°C)
	Spiral Wound	304 SS/Graphite	-320 to 750	-196 to 400	6250 psi (431 Bar)
	Spiral Wound	316 SS/Graphite	-320 to 1000 ⁽¹⁾	-196 to 538 ⁽¹⁾	6250 psi (431 Bar)
Optional Gaskets	Flat	AFG ⁽²⁾	-20 to 600	-28 to 315	CF ⁽³⁾
	Flat	KEL-F	-320 ⁽⁴⁾ to 350	-196 ⁽⁴⁾ to 177	6000 psi @ -320°F (415 Bar @ -196°C) / 1000 psi @ 350°F (69 Bar @ 177°C)
	Flat	PTFEG	-200 to 450	-130 to 232	6000 psi @ -200°F (415 Bar @ -130°C) / 500 psi @ 450°F (35 Bar @ 232°C)
	Spiral Wound	304 SS/AFG ⁽²⁾	-20 to 750	-28 to 400	6250 psi (431 Bar)
	Spiral Wound	316 SS/AFG ⁽²⁾	-20 to 1000	-28 to 538	6250 psi (431 Bar)
	Hollow O-Ring	Inconel X-750	-20 to 1500	-28 to 815	15000 psi (1034 Bar)

⁽¹⁾ Limited to 800°F (426°C) in oxidizing service. ⁽²⁾ Gasket material free of asbestos. ⁽³⁾ Contact factory for pressure limits of non-asbestos material specified. ⁽⁴⁾ Lower temperatures upon request.

BONNET TYPES

Standard Bonnet

The GL5 Series standard bonnet is usually manufactured with the same material as the valve body and withstands operating temperatures from -20 to 750°F (-28 to 400°C), depending on the packing material (see temperature limits for different packing materials on table IV).

Extended Bonnet

The extended bonnet protects the packing against excessive heat or cold that could affect the performance of the valve. The extended bonnet manufactured with carbon steel can be used with operating temperatures from -20 to 800°F (-28 to 426°C), and the extended bonnet manufactured with 304 or 316 stainless steel can work with operating temperatures from -150 to 1500°F (-100 to 815°C).

Extended Bonnet for Cold Box

The design of the GL5 Series extended bonnet for cold box allows that a small portion of the cryogenic liquid is vaporized and remains trapped inside the bonnet, creating a suitable temperature gradient that protects the packing. It is usually made from 304 or 316 stainless steel to withstand low temperatures down to -425°F (-253°C). For this kind of construction, the standard material for the bonnet flange and bolting is the stainless steel.

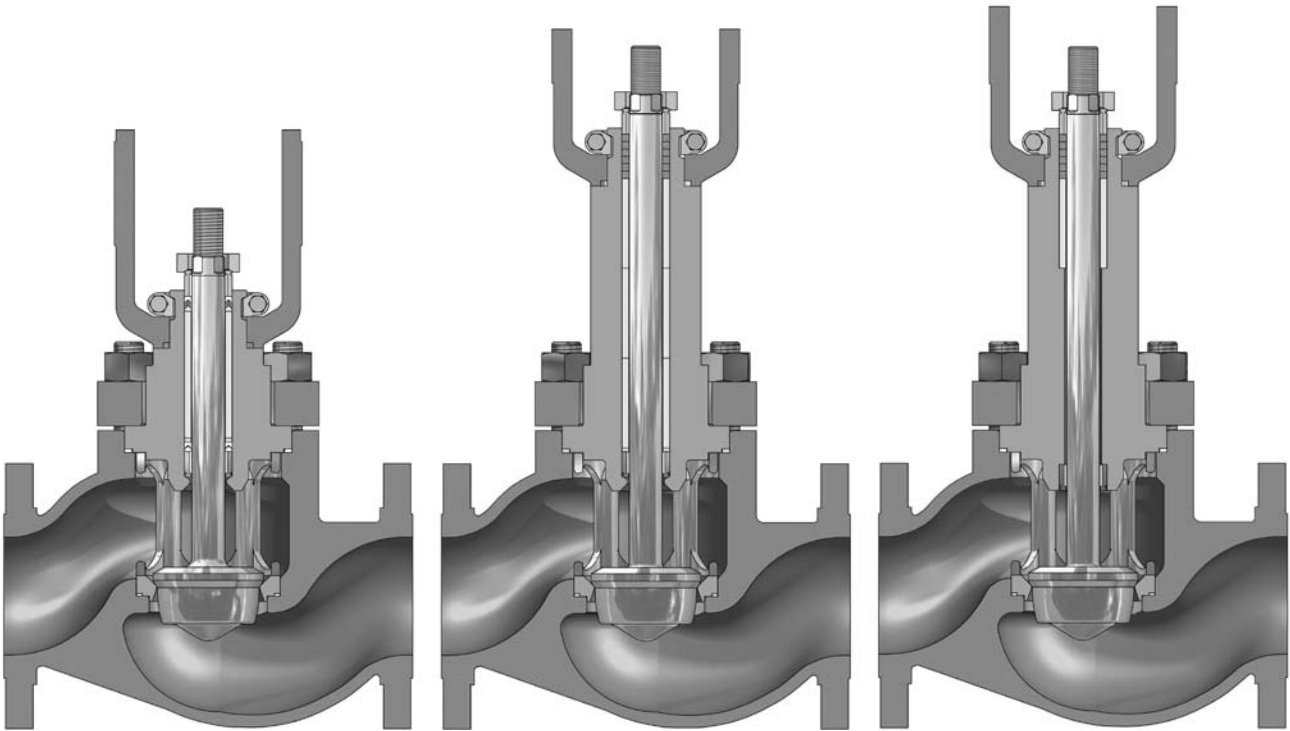

GL5 CONTROL VALVE - BONNET TYPES (FIGURE 11)

BONNET FLANGE AND BOLTING SPECIFICATIONS (TABLE III)

BONNET FLANGE (STANDARD)	BONNET FLANGE (OPTIONAL)	BONNET FLANGE STUDS & NUTS (STANDARD)	BONNET FLANGE STUDS & NUTS (OPTIONAL)
Carbon Steel	Stainless Steel ⁽¹⁾ or same material as body	ASTM A193 Gr. B7 / ASTM A194 Gr. 2H ⁽²⁾	304 or 316 Stainless Steel ⁽¹⁾⁽³⁾⁽⁴⁾

⁽¹⁾ Optional materials of bonnet flange and bonnet flange bolting are always necessary when exceeded the temperature limits of standard carbon steel or B7/2H. ⁽²⁾ Operating temperature from -20 to 800°F (-28 to 426°C), provided that the body limits are respected. ⁽³⁾ Operating temperature from -425 to 1500°F (-253 to 815°C), provided that the body limits are respected. ⁽⁴⁾ Other materials upon request, depending on operating conditions and design criteria.

Packing Box

The GL5 Valve packing box is deep and has excellent surface finish, allowing the use of all packing options offered by Valtek Sulamericana and bringing the following additional advantages:

1. The spacing between the lower wiper packing set and the upper packing set, which is effectively responsible for stem sealing, is so that wetted portion of plug stem do not reach the upper packing set.

2. Two large and widely spaced guides, located out of the flow path and a plug stem with large diameter comprise the advanced guiding system of the GL5 Series. The upper guide works also as a packing gland, while the lower guide, located next to the plug head, assures a sturdy alignment between the plug and the seat ring.

3. The options available for stem guides cover all application ranges and eliminate completely the problems related to friction between metallic parts.

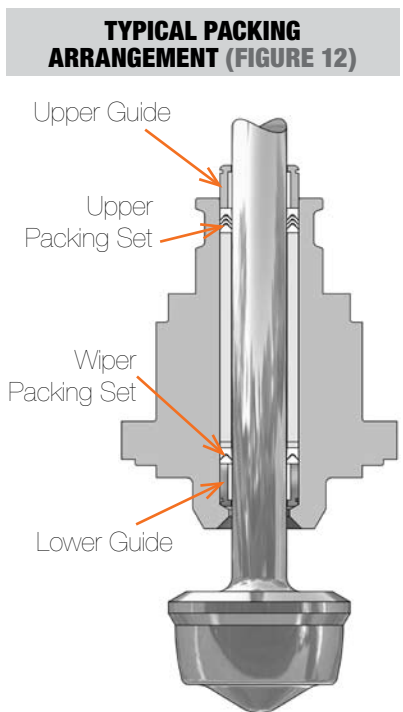

PACKING TEMPERATURE LIMITS (TABLE IV)			
BONNET TYPE	PACKING MATERIAL	TEMPERATURE LIMITS ⁽²⁾	
		°F	°C
Standard ⁽¹⁾	PTFE “V” Rings	-20 to 450	-28 to 232
	PT and PTG	-20 to 450	-28 to 232
	Braided PTFE	-20 to 500	-28 to 260
	Glass-filled PTFE (PTFEG)	-20 to 500	-28 to 260
	PTG XT	-20 to 550	-28 to 288
	Graphite/AFP ⁽³⁾	-20 to 750	-28 to 400
	Graphite/AFP ⁽³⁾ , Inconel wire	-20 to 750 ⁽⁴⁾	-28 to 400 ⁽⁴⁾
	Graphite ⁽⁵⁾	-20 to 750 ⁽⁴⁾	-28 to 400 ⁽⁴⁾
Extended ⁽¹⁾	PTFE “V” Rings	-150 to 600	-100 to 316
	PT and PTG	-20 to 600	-28 to 316
	Braided PTFE	-150 to 600	-100 to 316
	Glass-filled PTFE (PTFEG)	-150 to 600	-100 to 316
	PTG XT	-20 to 700	-28 to 371
	Graphite/AFP ⁽³⁾	-20 to 1200	-28 to 650
	Graphite/AFP ⁽³⁾ , Inconel wire	-20 to 1200	-28 to 650
	Graphite ⁽⁵⁾	-20 to 1500	-28 to 815
Cryogenic ⁽¹⁾	PTFE, with 15 or 18 in. extension length	-320	-196
	PTFE, with 24 or 27 in. extension length	-425	-253

⁽¹⁾ ANSI B16.34 specifies acceptable pressure and temperature limits for pressure retaining materials. Contact manufacturer for additional information about the pressure vs. temperature limits of packings. ⁽²⁾ Temperature limits are valid provided that the pressure vs. temperature limits of body, bonnet and remaining parts are respected. ⁽³⁾ High temperature packing, free of asbestos. ⁽⁴⁾ For sizes from 8 to 12 inches, the maximum temperature limit is 850°F (454°C). ⁽⁵⁾ Do not use graphite packing in oxidizing services such as air or oxygen with operating temperatures higher than 750°F (400°C). Due to the increased friction, the use of graphite packing may require the use of extra-strong springs and/or oversized actuators.

TEMPERATURE AND PRESSURE LIMITS FOR PLUG GUIDES/INSERTS (TABLE V)			
GUIDE/INSERT MATERIALS	TEMPERATURE LIMITS		PRESSURE LIMITS
	°F	°C	
Stainless Steel with Graphite Insert ^{(1) (2)}	-320 to 1500 ⁽³⁾	-196 to 815 ⁽³⁾	up to 1000 psi (69.0 Bar) for sizes up to 2 in. up to 600 psi (41.4 Bar) for sizes 3 and 4 in. up to 500 psi (34.5 Bar) for sizes 6 in. and larger
Stainless Steel with PTFEG Insert	-20 to 300	-28 to 150	850 psi @ 100°F (58.6 Bar @ 38°C); 100 psi @ 300°F (6.9 Bar @ 150°C)
Bronze (solid guide) ⁽⁴⁾	-425 to 500 ⁽⁵⁾	-253 to 260 ⁽⁵⁾	Body rating
Alloy #6 (solid guide) ⁽⁶⁾	-425 to 1500	-253 to 815	Body rating

⁽¹⁾ The ΔP through the valve must be observed for each valve size. Contact factory. ⁽²⁾ Do not use in oxygen enriched services. In applications under cavitation condition, the use of lower guide with graphite insert is not recommended. ⁽³⁾ For oxidizing services such as air, the maximum operating temperature is 800°F (426°C). ⁽⁴⁾ Bronze solid guides shall not be used in corrosive applications or where NACE certification is required. ⁽⁵⁾ For upper guide, the maximum temperature limit is 900°F (482°C). ⁽⁶⁾ Whenever the valve trim is a 300 series stainless steel and the lower guide made from Alloy #6 is specified, the plug stem must be hardened with Alloy #6 in the stem region in contact with the lower guide.

PT Packing

The GL5 Series PT packing comply with EPA* regulations regarding fugitive emissions in packings.

Comprised by virgin PTFE V-rings combined with carbon-filled PTFE V-rings, the PT packing is compressed by means of a Belleville washers set that causes a “live load” effect, and is available for the majority of the control valves manufactured by Valtek Sulamericana, assuring emissions levels lower than 500 ppm.

With a simple configuration and easy to replace, the PT packing does not require retightening due to the pressure and temperature variations in the process.

Optionally, a fire-safe version of PT packing is available, which guarantees no leaks through the stem, even with the damages caused to V-rings by the excessive heat.

PTG and PTG XT Packing

When the operating temperature exceeds the recommended limits of PT packing or even when a higher sealing capacity is expected, the PTG packing is the ideal choice.

To comply with EPA* regulations, PTG packing assures emission levels much lower than 500 ppm (usually 10 ppm), making it a highly reliable and economical option instead of using metal bellows seals.

The PTG packing set can be installed in all valves supplied by Valtek Sulamericana, offering long useful life with reduced need for retightening the packing set.

Optionally, the PTG packing set may be supplied in a fire-safe version, in accordance to the requirements of API 607.

For higher operating temperatures the PTG XT is indicated, and its application limits are indicated on table IV.

* EPA = Environmental Protection Agency

PT PACKING SYSTEM (FIGURE 13)

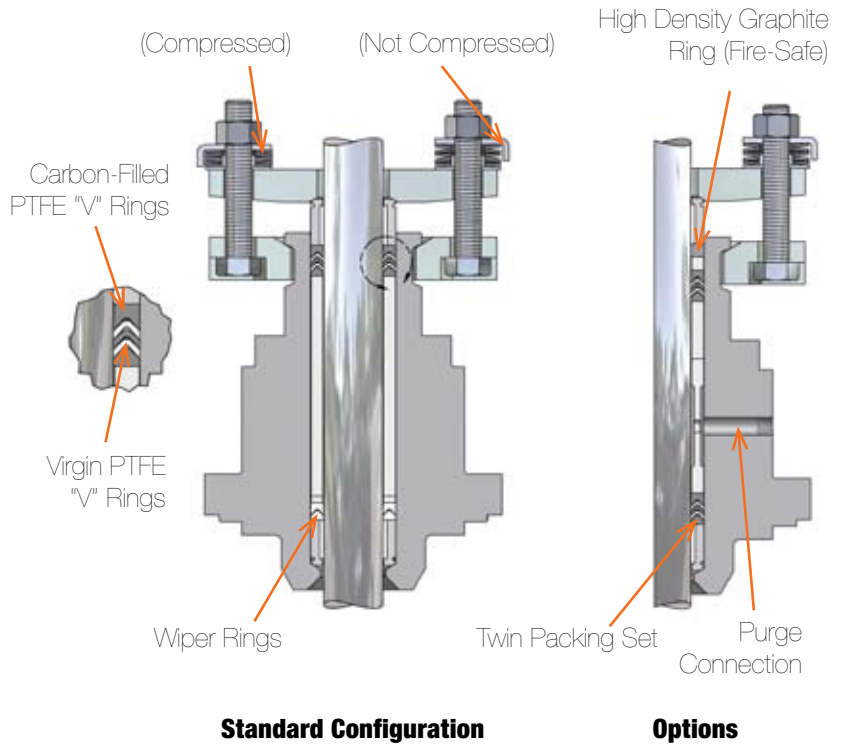

PTG & PTG XT PACKING SYSTEMS (FIGURE 14)

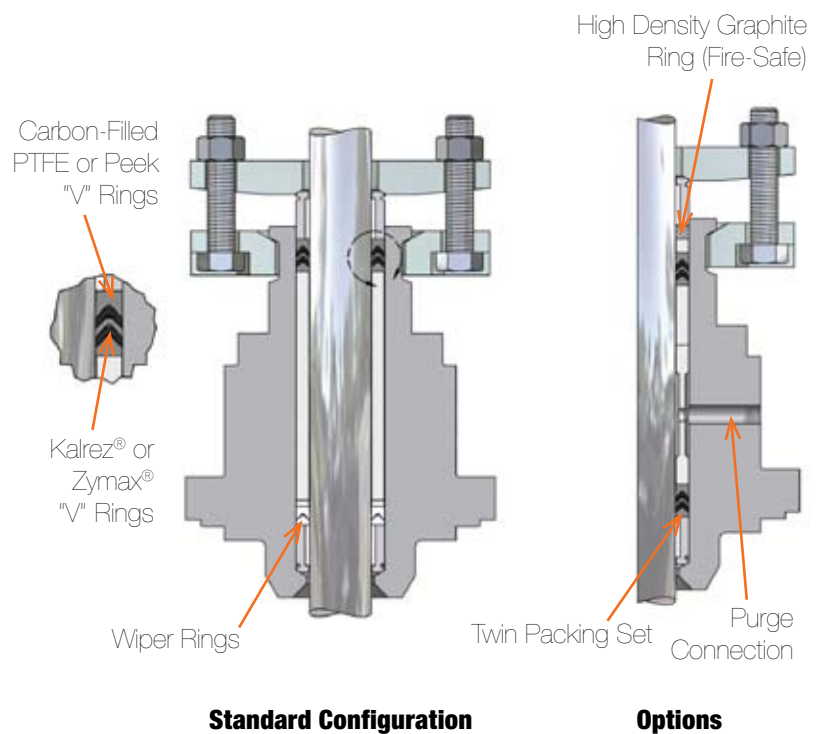

Trim

The GL5 Series Trim is developed to eliminate the issues normally associated to valves with threaded seats or with cage-guided plug design. Since the seat is not threaded, but it is fixed onto the body by means of the bonnet and the seat retainer, its removal is quite simple, even when the valve operates in corrosive conditions.

Different from trim with a guide in the seat retainer, which easily present wear and jamming, the GL5 Series trim is guided by a double upper guide system that avoids the contact between the seat retainer and the plug. Since there is no direct contact with the plug, the retainer may be manufactured in stainless steel, instead of costly hardened materials. The flow characteristic is determined by the plug shape, instead of by openings located in the retainer.

For services with very high differential pressures, pressure-balanced trim is used to reduce the thrust needed to stroke the plug through the reduction of trim off-balance areas.

The valves with pressure-balanced trim shall be used with clean fluids only, considering also that flow direction for the safety fail-closed position is under the plug and, for fail-open position is over the plug.

Optionally, the GL5 Series may be supplied with special trim to attenuate the noise level and for applications under cavitation conditions.

UNBALANCED TRIM (FIGURE 15)

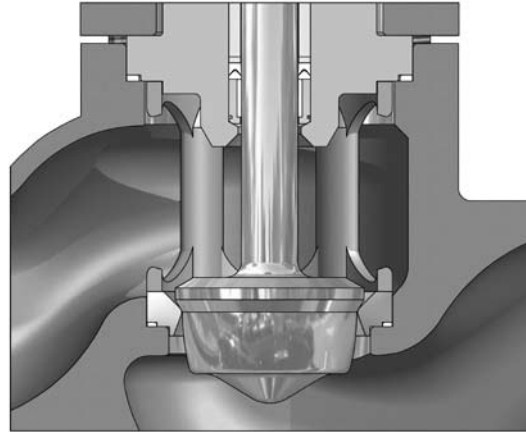

PRESSURE-BALANCED TRIM (FIGURE 16)

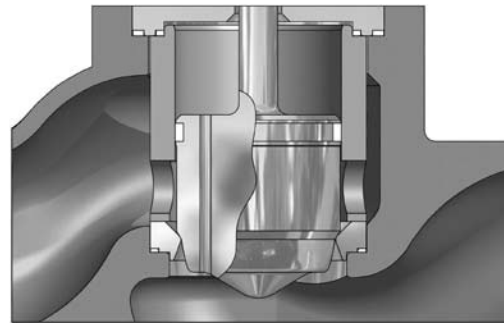

SPECIFICATION GUIDE FOR PRESSURE-BALANCED PLUG SEALS (TABLE VI)

MATERIAL OF PLUG SEALS ⁽¹⁾	TEMPERATURE LIMITS ⁽²⁾		SHUTOFF CLASS	
	°F	°C	WITH METAL SEAT	WITH SOFT SEAT
PTFE Seals	0 to 350	-18 to 176	up to 10% of Class IV	up to 1% of Class IV
Reinforced PTFE Seals	0 to 400	-18 to 204	up to 10% of Class IV	up to 1% of Class IV
Buna-N O-Ring	-40 to 200	-40 to 93	Class IV or V	Class VI
Viton-A O-Ring	-10 to 400	-23 to 204	Class IV or V	Class VI
VMG Metal Seals Sizes from 2 to 4 in. Sizes 6 in. and larger	300 to 1600	149 to 871	Class III	N/A
	300 to 1600	149 to 871	Class IV	N/A

⁽¹⁾ Whenever used metal seals such as VMG, the bore surface of pressure-balanced sleeve must be hardened. ⁽²⁾ The temperature limits above are for information purposes only. Contact Valtek Sulamericana to confirm the maximum allowable temperature regarding the operating pressure.

Metal Seats

The GL5 valve standard configuration, with unbalanced trim and metal seat comply with ANSI B16.104/FCI 70.2 class IV that specifies a maximum allowable leakage of 0.01% of nominal valve capacity.

The exceptional sealing capacity of the GL5 Series is easily reached due to its self-centering seat design. A superior sealing class is available as an option.

Soft Seats

Soft seats are used in applications requiring extreme tightness, complying with ANSI B16.104/FCI 70.2 class VI. The GL5 soft seat is comprised by a polymer assembled between two metal pieces, and it is interchangeable with the metal seat. The soft seat inserts are usually manufactured in PTFE and, therefore, the maximum operating temperature shall be lower than 300°F @ 290 psig (150°C @ 20 Barg).

For temperatures below -85°F (-65°C), soft seats may be used in high-pressure applications.

TRIM DATA, SEATS

Trim Data

STANDARD UNBALANCED TRIM AND ACTUATOR DATA (TABLE VII)

VALVE SIZE (Inches)	ANSI CLASS	FULL AREA TRIM SIZE		SEAT AREA		STEM DIAMETER		STEM AREA		STROKE		STANDARD ACTUATOR SIZE
		in.	mm	in. ²	cm ²	in.	mm	in. ²	cm ²	in.	mm	
0.5	150-600	0.50	13	0.196	1.267	0.575	14.6	0.259	1.674	0.75	19.05	25
0.75	150-600	0.71	18	0.405	2.612	0.575	14.6	0.259	1.674	0.75	19.05	25
1	150-600	0.81	21	0.518	3.345	0.575	14.6	0.259	1.674	0.75	19.05	25
1.5	150-600	1.25	32	1.227	7.917	0.890	22.6	0.622	4.011	1.00	25.40	25
2	150-600	1.63	41	2.074	13.38	0.890	22.6	0.622	4.011	1.50	38.10	25
3	150-600	2.63	67	5.412	34.92	1.138	28.9	1.017	6.560	2.00	50.80	50
4	150-600	3.50	89	9.621	62.07	1.138	28.9	1.017	6.560	2.50	63.50	50
6	150	5.00	127	19.63	126.7	1.138	28.9	1.017	6.560	3.00	76.20	50
	300-600	5.00	127	19.63	126.7	2.024	51.4	3.216	20.75	3.00	76.20	100
8	150	6.25	159	30.68	198.0	1.520	38.6	1.814	11.70	4.00	101.6	100
	300-600	6.25	159	30.68	198.0	2.024	51.4	3.216	20.75	4.00	101.6	100
10	150	8.00	203	50.27	324.3	2.024	51.4	3.216	20.75	4.00	101.6	100
	300-600	8.00	203	50.27	324.3	2.524	64.1	5.002	32.27	4.00	101.6	100
12	150	9.50	241	70.88	457.3	2.024	51.4	3.216	20.75	4.00	101.6	100
	300-600	9.50	241	70.88	457.3	3.024	76.8	7.180	46.32	4.00	101.6	100

PRESSURE-BALANCED TRIM AND ACTUATOR DATA (TABLE VIII)

VALVE SIZE (Inches)	ANSI CLASS	FULL AREA TRIM SIZE		SEAT AREA		STEM DIAMETER		STEM AREA		SLEEVE AREA		OFF-BALANCE AREA				STROKE		STANDARD ACTUATOR SIZE
												TENDING TO CLOSE (Flow Under)		TENDING TO OPEN (Flow Over)				
		in.	mm	in. ²	cm ²	in.	mm	in. ²	cm ²	in. ²	cm ²	in. ²	cm ²	in. ²	cm ²	in.	mm	
2	150-600	1.63	41	2.074	13.38	0.575	14.6	0.259	1.674	2.58	16.65	0.25	1.60	0.51	3.28	1.00	25.4	25
3	150-600	2.63	67	5.412	34.92	0.890	22.6	0.622	4.011	6.77	43.68	0.74	4.75	1.36	8.78	1.50	38.1	50
4	150-600	3.50	89	9.621	62.07	0.890	22.6	0.622	4.011	11.41	73.61	1.17	7.53	1.79	11.6	2.00	50.8	50
6	150	5.00	127	19.63	126.7	1.138	28.9	1.017	6.560	22.69	146.4	2.04	13.1	3.06	19.7	2.50	63.5	50
	300-600	5.00	127	19.63	126.7	1.520	38.6	1.814	11.70	23.76	153.3	2.32	14.9	4.13	26.6	2.50	63.5	100
8	150-600	6.25	159	30.68	198.0	1.520	38.6	1.814	11.70	35.78	230.8	3.29	21.1	5.10	32.9	3.00	76.2	100
10	150-600	8.00	203	50.27	324.3	2.024	51.4	3.216	20.75	58.36	376.5	4.87	31.5	8.09	52.2	3.00	76.2	100
12	150-600	9.50	241	70.88	457.3	2.524	64.1	5.002	32.27	82.52	532.4	6.64	42.8	11.6	75.1	4.00	102	100

Seats



Soft Seat Configuration

Seat Surface



Full Bore



GL5 SERIES - SEAT OPTIONS (FIGURE 17)

TRIM, MATERIALS

The standard manufacturing material for the GL5 plug, seat and seat retainer is 316 stainless steel, except in case of valves manufactured with special alloys, when the trim is usually manufactured with the same material as the body. A large quantity of fluids is compatible with 316 stainless steel trim. However, as a general rule, hardened trim shall be used for all conditions of critical flow or in services where the operating temperature exceeds 600°F (316°C). Valtek Sulamericana maintains a large stock of trim manufactured in Alloy #6. This material offers a good combination of hardness and corrosion resistance.

Special alloys such as Alloy 20, Monel, Hastelloy C, Hastelloy B and other materials may be supplied upon request.

PLUG - HARD FACING VARIATIONS (FIGURE 18)

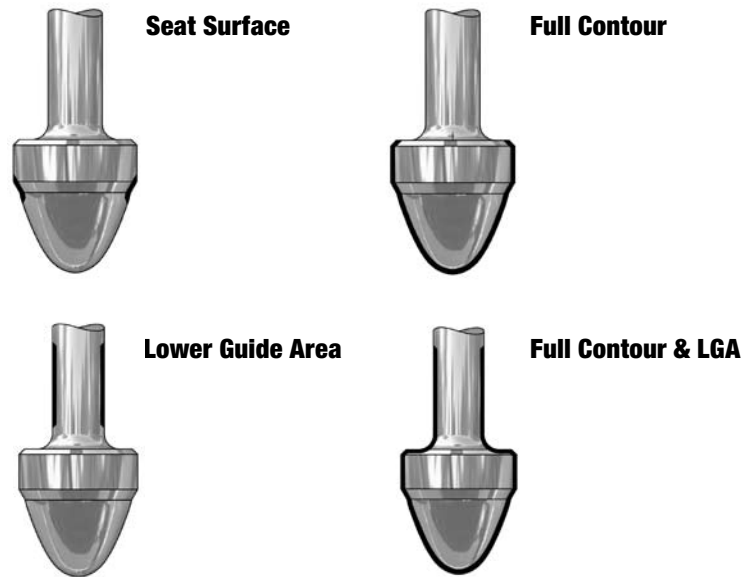

DIFFERENTIAL PRESSURE VALUES REQUIRING HARDENED TRIM (TABLE IX)

VALVE SIZE (Inches)	WATER				STEAM (SATURATED)				STEAM (SUPER-HEATED)				PROCESS FLUIDS (GENERAL)				CLEAN GASES			
	Throttling		On-Off		Throttling		On-Off		Throttling		On-Off		Throttling		On-Off		Throttling		On-Off	
	psi	Bar	psi	Bar	psi	Bar	psi	Bar	psi	Bar	psi	Bar	psi	Bar	psi	Bar	psi	Bar	psi	Bar
0.5 to 1.5	175	12.1	250	17.2	100	6.9	200	13.8	300	20.7	600	41.4	175	12.1	250	17.2	600	41.4	900	62.1
2 & 3	150	10.3	200	13.8	25	1.7	50	3.4	200	13.8	300	20.7	150	10.3	200	13.8	350	24.1	600	41.4
4 & 6	100	6.9	125	8.6	All Apps.		25	1.7	100	6.9	150	10.3	75	5.2	125	8.6	200	13.8	300	20.7
8 to 12	50	3.4	100	6.9	All Apps.		All Apps.		50	3.4	100	6.9	50	3.4	100	6.9	125	8.6	175	12.1

CHARACTERISTICS OF TRIM MATERIALS (TABLE X)

TRIM MATERIALS	HARDNESS (R _c)	MAX. RECOMMENDED TEMPERATURE		IMPACT STRENGTH	CORROSION RESISTANCE	EROSION RESISTANCE	ABRASION RESISTANCE
		°F	°C				
316 Stainless Steel	8	600	316	Excellent	Excellent	Fair	Fair
Alloy #6	44	1500	815	Excellent	Excellent	Good	Good
416 Stainless Steel	40	800	426	Good	Fair	Good	Good
17-4 PH (H900)	44	800	426	Good	Good to Excellent	Good	Good
440C Stainless Steel	55-60	800	426	Fair	Fair	Excellent	Excellent
Monel K-500	32	600	316	Good	Good to Excellent	Fair to Good	Good
Tungsten	72	1200	650	Fair	Good on Bases, Poor on Acids	Excellent	Excellent
Colmonoy #5	45-50	1200	650	Good	Fair	Good	Good

GL₅ SERIES - SPECIFICATIONS & MATERIALS OF CONSTRUCTION (TABLE XI)

BODY	Sizes	0.5 to 48 inches		
	ANSI Ratings	150, 300 and 600		
	Forms	Globe, angle, 3-Way or steam jacketed versions		
	Materials of Construction	Carbon steel, stainless steel, chrome-moly steel, Alloy 20, bronze, Monel, Hastelloy B, Hastelloy C, nickel, titanium and other castable alloys upon request		
	End Connections	Separable flanges (0.5 to 4 inches) Integral flanges (all sizes) NPT threaded (0.5 to 2 inches) Socketweld (0.5 to 4 inches) Buttweld (all sizes) Grayloc (all sizes)		
	Separable Flanges	Carbon steel, 316 stainless steel or other materials upon request		
	Gaskets	Flat	PTFE, PTFEG*, KEL-F	
Spiral Wound		316 or 304 SS spiral wound with graphite, PTFE or other filler materials free of asbestos (AFG)		
O-Rings		Inconel X-750 / silver plated hollow O-Ring		
BONNET	Types	Standard, extended, criogenic with special length extension		
	Materials	Same as body		
	Bonnet Flange	Separable, made from carbon steel or 316 stainless steel		
	Guides	Type	Double upper guide on plug stem, out of flow path	
		Materials	316 SS with PTFEG* or graphite insert, bronze, Alloy #6 or other materials available upon request	
Packings	Types	Standard with "V" or square rings, twin seal, packing for vacuum applications		
	Materials	PTFE V-rings, PTFEG* V-rings, braided PTFE, AFP** with Inconel wire, graphite and other materials upon request		
TRIM	Types	Unbalanced Pressure-balanced, with elastomer, polymer or metal plug seals		
	Flow Characteristics	Equal Percentage, Linear or Quick Open		
	Materials	316 SS (standard), 304 SS, 347 SS, 416 SS, 420 SS, 440C SS, Alloy 20, Monel, Hastelloy B, Hastelloy C, 17-4 PH, nickel, titanium and others		
	Hard Facings	Materials	Alloy #6, Colmonoy #5 or other materials upon request	
		Types	Hardening of seating surfaces, hardening of plug full contour and seat full bore, hardening of plug stem region in contact with the lower guide	
Soft Seats	Materials	PTFE, PTFEG*, FEP, KEL-F, polyurethane, PEEK		
ACTUATOR	Types	Pneumatic	Double-acting cylinder with positive spring for failsafe action. Field reversible and available on sizes 25, 50, 100, 200, 300, 400, 500 and 600. Options: manual handwheel, limit stops and others (see the technical bulletin of linear actuators).	
		Others	Manual, electro-mechanical or electro-hydraulic upon request	
POSITIONER	Types	Pneumatic, analog electro-pneumatic or digital electro-pneumatic with multiple communication protocols		

*PTFEG: Glass-Filled PTFE. ** AFP: Asbestos-free packing.

Equal Percentage

The Equal Percentage is the most common characteristic used in processes control. The flow rate change by valve stroke unit is directly proportional to the flow rate passing through the valve at the moment immediately before the stroke movement. When installed, a valve with an Equal Percentage characteristic will present in most control loops, a characteristic close to the Linear characteristic, whenever the total differential pressure of the system is large compared to the differential pressure through the valve.

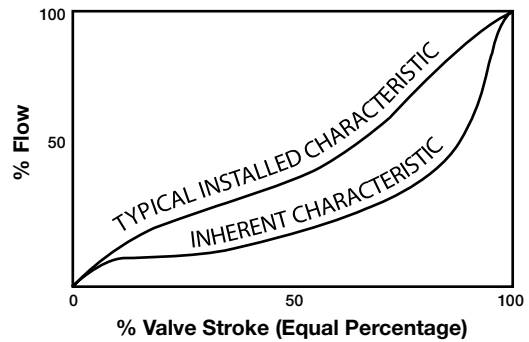

Linear

The Linear characteristic creates equal changes in flow rate per unit of valve stroke, regardless of plug position. Linear plugs are frequently used in systems where the differential pressure through the valve corresponds to the major part of the total differential pressure of the system.

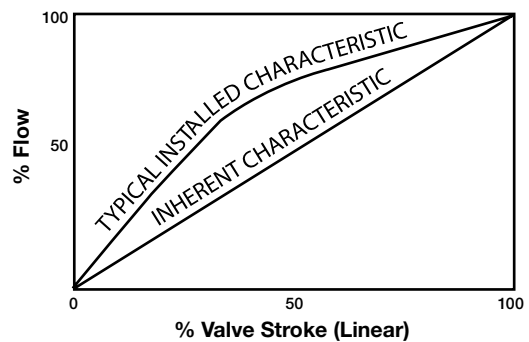

Quick-open

Quick-open plugs are used in on-off services and are designed to create large increments of flow rate, even from small opening percentages.

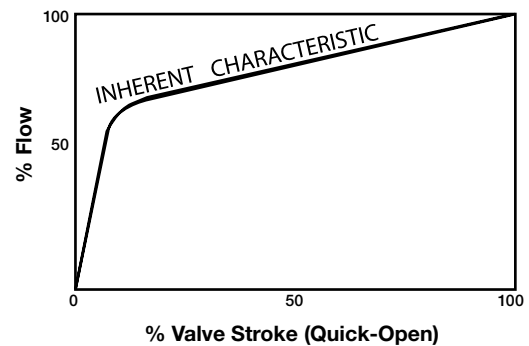

Trim Sizes

Two sizes of trim are normally available: a standard one, with full-area and another one with reduced area, available in a great variety of dimensions, and necessary when the required C_v , due to the process conditions, is relatively too small for a specific body size intended to be used. In addition to these options, an integral trim may be supplied, which uses a special seat machined onto the valve body and an oversized plug to provide an even larger C_v than the C_v provided by the standard full-area trim.

Since the GLS valve trim is completely interchangeable for a specific body size and pressure class, the change of trim size and valve nominal C_v is a very simple operation.

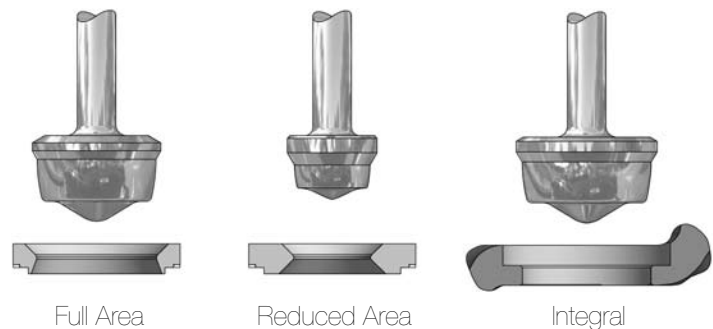

TRIM SIZES (FIGURE 19)

FLOW COEFFICIENTS

Flow Direction: Over the Plug

FLOW COEFFICIENTS (C _v) - EQUAL PERCENTAGE * (TABLE XII)													
VALVE SIZE (inches)	TRIM SIZE (TN)	STROKE		C _v AT PERCENT OPEN									
		in.	mm	100	90	80	70	60	50	40	30	20	10
0.5	0.50 (13)	0.75	19.05	5.0	4.6	3.7	2.6	1.86	1.36	0.90	0.55	0.33	0.25
	0.38 (10)	0.75	19.05	3.7	3.3	2.5	1.63	1.23	0.85	0.49	0.31	0.189	0.127
	0.31 (8)	0.75	19.05	2.8	2.5	1.76	1.22	0.94	0.58	0.33	0.22	0.149	0.095
	0.25-03 (6.5-03)	0.75	19.05	1.94	1.60	1.08	0.81	0.56	0.37	0.23	0.142	0.090	0.060
	0.25-06 (6.5-06)	0.75	19.05	1.25	1.03	0.70	0.52	0.36	0.24	0.147	0.092	0.058	0.038
	0.12-00 (3.2-00)	0.50	12.70	0.46	0.45	0.38	0.27	0.168	0.103	0.072	0.043	0.026	0.015
0.75	0.71 (18)	0.75	19.05	9.5	9.0	7.6	5.6	3.9	3.2	2.3	1.61	1.00	0.63
	0.63 (16)	0.75	19.05	9.0	8.3	6.6	4.6	3.0	2.3	1.57	0.94	0.59	0.32
	0.50 (13)	0.75	19.05	6.5	5.9	4.7	3.0	2.0	1.54	0.98	0.63	0.37	0.24
	0.38 (10)	0.75	19.05	4.2	3.7	2.9	1.75	1.38	0.87	0.46	0.29	0.165	0.106
	0.31 (8)	0.75	19.05	2.9	2.6	1.65	1.23	0.88	0.59	0.31	0.20	0.151	0.093
	0.25-03 (6.5-03)	0.75	19.05	1.98	1.83	1.22	0.91	0.57	0.35	0.21	0.140	0.087	0.059
	0.25-06 (6.5-06)	0.75	19.05	1.28	1.26	0.96	0.63	0.37	0.23	0.131	0.087	0.051	0.024
	0.12-00 (3.2-00)	0.50	12.70	0.47	0.47	0.37	0.24	0.151	0.088	0.056	0.036	0.018	0.006
1	0.81 (21)	0.75	19.05	15.6	14.2	11.3	8.1	4.9	3.3	2.8	2.1	1.61	1.07
	0.71 (18)	0.75	19.05	13.5	11.8	8.9	6.1	3.9	3.1	2.3	1.65	1.12	0.70
	0.63 (16)	0.75	19.05	10.3	8.7	6.5	4.2	2.7	2.3	1.53	0.98	0.61	0.35
	0.50 (13)	0.75	19.05	6.6	5.8	4.5	2.9	2.0	1.55	1.10	0.73	0.47	0.26
	0.38 (10)	0.75	19.05	4.1	3.4	2.3	1.54	1.31	0.85	0.51	0.33	0.22	0.140
	0.31 (8)	0.75	19.05	2.9	2.4	1.64	1.16	0.93	0.61	0.35	0.20	0.138	0.089
	0.25-03 (6.5-03)	0.75	19.05	1.87	1.53	1.08	0.82	0.55	0.31	0.21	0.132	0.082	0.055
	0.25-06 (6.5-06)	0.75	19.05	1.26	1.24	0.94	0.63	0.37	0.23	0.129	0.085	0.051	0.024
	0.12-00 (3.2-00)	0.50	12.70	0.47	0.46	0.29	0.22	0.158	0.113	0.085	0.063	0.043	0.026
1.5	1.25 (32)	1.00	25.40	28	26	21	15.6	10.3	6.7	5.0	3.6	2.3	1.57
	1.00 (25)	0.75	19.05	19.1	17.3	14.5	10.9	7.2	4.5	3.3	2.4	1.57	1.06
	0.81 (21)	0.75	19.05	12.8	11.3	8.9	6.3	4.0	2.6	1.76	1.05	0.69	0.33
	0.63 (16)	0.75	19.05	7.8	6.7	5.2	3.7	2.5	1.7	1.15	0.64	0.40	0.22
	0.38 (10)	0.75	19.05	3.6	2.8	1.94	1.42	1.24	0.87	0.58	0.30	0.182	0.109
2	1.63 (41)	1.50	38.10	46	41	34	25	16.3	11.4	9.1	5.9	3.8	2.6
	1.25 (32)	1.00	25.40	31	27	22	16.0	10.3	6.6	5.2	3.6	2.3	1.56
	1.00 (25)	0.75	19.05	21	18.5	15.3	11.2	7.5	4.7	3.3	2.5	1.58	1.06
	0.81 (21)	0.75	19.05	13.7	12.2	9.8	7.0	4.4	2.8	2.2	1.45	0.94	0.64
	0.63 (16)	0.75	19.05	9.0	8.0	6.2	4.2	2.6	2.0	1.44	0.89	0.53	0.31
	0.38 (10)	0.75	19.05	3.6	3.3	2.6	1.76	1.17	0.93	0.56	0.35	0.22	0.152
3	2.63 (67)	2.00	50.80	105	96	86	77	61	38	22	16.4	10.3	5.9
	2.00 (51)	1.50	38.10	79	74	67	56	41	24	13.5	8.9	6.4	3.7
	1.63 (41)	1.50	38.10	51	45	35	24	15.5	10.3	8.2	5.6	3.5	2.5
	1.25 (32)	1.00	25.40	32	28	23	15.8	10.5	6.8	5.1	3.5	2.3	1.48
4	3.50 (89)	2.50	63.50	180	170	155	131	97	57	35	26	20	13.0
	2.63 (67)	2.00	50.80	133	124	111	89	63	39	24	16.3	11.4	7.4
	2.25 (57)	2.00	50.80	103	95	82	62	40	24	14.9	11.6	7.3	4.6
	1.63 (41)	1.50	38.10	56	49	38	25	16.3	10.7	8.6	5.8	3.7	2.5
6	5.00 (127)	3.00	76.20	356	334	303	265	203	125	59	33	20	13.9
	3.50 (89)	2.50	63.50	231	216	193	153	102	58	35	23	17.5	11.1
	3.00 (76)	2.00	50.80	191	153	120	101	61	38	26	16.9	11.9	7.9
	2.63 (67)	2.00	50.80	139	131	117	94	64	37	22	16.3	10.9	6.8
8	6.25 (159)	4.00	101.6	608	566	501	414	306	182	107	73	55	34
	5.00 (127)	3.00	76.20	462	429	370	291	202	125	59	33	20	14.0
	3.50 (89)	2.50	63.50	248	231	203	160	109	61	34	21	13.0	6.9
	2.63 (67)	2.00	50.80	142	133	117	94	64	36	22	15.8	10.8	6.9
10	8.00 (203)	4.00	101.6	900	846	765	658	527	372	193	99	60	42
	6.25 (159)	4.00	101.6	687	632	546	423	304	180	107	73	49	34
	5.00 (127)	3.00	76.20	491	451	382	288	200	124	59	33	19.8	13.9
12	9.50 (241)	4.00	101.6	1306	1211	1077	917	695	427	229	153	108	73
	7.38 (187)	4.00	101.6	962	886	752	586	422	251	149	101	68	46
	6.25 (159)	4.00	101.6	771	713	590	441	305	181	107	73	49	34

* Data above refer to the valves with unbalanced trim. Consult Valtek Sulamericana to obtain information regarding the C_v of pressure-balanced valves.

Flow Direction: Under the Plug

FLOW COEFFICIENTS (C_v) - EQUAL PERCENTAGE * (TABLE XIII)

VALVE SIZE (inches)	TRIM SIZE (TN)	STROKE		C _v AT PERCENT OPEN									
		in.	mm	100	90	80	70	60	50	40	30	20	10
0.5	0.50 (13)	0.75	19.05	4.9	4.7	3.9	2.3	1.64	1.07	0.72	0.45	0.30	0.20
	0.38 (10)	0.75	19.05	3.5	3.1	2.3	1.52	1.01	0.69	0.41	0.27	0.180	0.131
	0.31 (8)	0.75	19.05	2.5	2.2	1.64	1.07	0.70	0.46	0.28	0.21	0.148	0.106
	0.25-03 (6.5-03)	0.75	19.05	1.76	1.55	1.02	0.66	0.43	0.27	0.176	0.108	0.074	0.048
	0.25-06 (6.5-06)	0.75	19.05	1.18	1.16	0.81	0.50	0.33	0.20	0.134	0.092	0.068	0.059
	0.12-00 (3.2-00)	0.50	12.70	0.44	0.43	0.41	0.25	0.160	0.100	0.067	0.044	0.029	0.017
0.75	0.71 (18)	0.75	19.05	9.5	8.9	7.5	5.5	3.2	2.2	1.38	0.94	0.67	0.43
	0.63 (16)	0.75	19.05	8.5	8.4	6.3	4.3	2.8	1.78	1.23	0.75	0.45	0.27
	0.50 (13)	0.75	19.05	6.1	5.8	4.7	2.9	1.87	1.20	0.77	0.47	0.30	0.183
	0.38 (10)	0.75	19.05	3.7	3.4	2.7	1.72	1.10	0.70	0.42	0.27	0.160	0.096
	0.31 (8)	0.75	19.05	2.7	2.4	1.64	1.10	0.70	0.45	0.26	0.181	0.126	0.081
	0.25-03 (6.5-03)	0.75	19.05	1.88	1.80	1.27	0.83	0.47	0.31	0.193	0.124	0.079	0.051
1	0.25-06 (6.5-06)	0.75	19.05	1.18	1.17	0.76	0.50	0.32	0.184	0.112	0.064	0.035	0.013
	0.12-00 (3.2-00)	0.50	12.70	0.46	0.46	0.45	0.27	0.159	0.092	0.057	0.034	0.015	0.004
	0.81 (21)	0.75	19.05	13.5	12.3	9.3	6.6	4.1	2.8	1.87	1.29	0.95	0.66
	0.71 (18)	0.75	19.05	12.3	11.4	8.0	5.6	3.5	2.3	1.55	1.04	0.69	0.46
	0.63 (16)	0.75	19.05	9.8	9.1	6.1	3.9	2.5	1.69	1.11	0.70	0.45	0.29
	0.50 (13)	0.75	19.05	6.6	5.9	4.5	2.7	1.80	1.19	0.78	0.47	0.29	0.195
1.5	0.38 (10)	0.75	19.05	3.9	3.4	2.3	1.49	0.98	0.65	0.43	0.29	0.193	0.129
	0.31 (8)	0.75	19.05	2.8	2.4	1.63	1.08	0.72	0.48	0.26	0.179	0.125	0.080
	0.25-03 (6.5-03)	0.75	19.05	1.80	1.58	1.13	0.70	0.46	0.29	0.186	0.137	0.082	0.058
	0.25-06 (6.5-06)	0.75	19.05	1.18	1.04	0.73	0.46	0.31	0.177	0.116	0.083	0.048	0.032
	0.12-00 (3.2-00)	0.50	12.70	0.51	0.50	0.33	0.194	0.126	0.085	0.061	0.040	0.025	0.014
	1.25 (32)	1.00	25.40	31	29	25	16.3	11.0	7.0	4.5	3.0	1.91	1.30
2	1.00 (25)	0.75	19.05	22	22	16.7	10.9	6.6	4.5	3.0	1.90	1.32	0.91
	0.81 (21)	0.75	19.05	15.8	13.7	9.4	6.1	4.5	2.6	1.58	0.93	0.59	0.33
	0.63 (16)	0.75	19.05	10.0	8.2	6.3	5.3	3.2	1.91	1.08	0.77	0.43	0.27
	0.38 (10)	0.75	19.05	3.7	3.2	1.95	1.31	0.88	0.60	0.36	0.23	0.142	0.088
	1.63 (41)	1.50	38.10	47	45	41	30	16.4	10.6	7.0	4.6	3.1	2.2
	1.25 (32)	1.00	25.40	30	29	24	15.6	10.1	6.4	4.3	2.8	1.86	1.25
3	1.00 (25)	0.75	19.05	23	22	17.7	11.4	6.7	4.6	3.0	1.89	1.27	0.88
	0.81 (21)	0.75	19.05	17.5	17.1	12.5	7.9	5.1	3.3	2.1	1.35	0.93	0.61
	0.63 (16)	0.75	19.05	10.1	9.1	6.7	4.5	2.7	1.80	1.16	0.74	0.44	0.28
	0.38 (10)	0.75	19.05	3.1	2.9	2.6	1.95	1.24	0.81	0.50	0.33	0.21	0.147
	2.63 (67)	2.00	50.80	109	102	93	89	72	36	21	12.9	7.9	4.5
	2.00 (51)	1.50	38.10	83	78	72	64	44	25	13.8	8.8	5.3	3.3
4	1.63 (41)	1.50	38.10	48	46	41	27	17.0	11.2	7.2	4.7	3.1	2.2
	1.25 (32)	1.00	25.40	32	31	25	16.3	10.6	7.0	4.5	2.9	1.90	1.29
	3.50 (89)	2.50	63.50	196	184	169	157	115	57	36	24	15.4	10.7
	2.63 (67)	2.00	50.80	132	122	110	99	66	42	27	17.2	10.3	6.7
	2.25 (57)	2.00	50.80	97	89	80	66	41	26	16.3	10.3	6.2	4.2
	1.63 (41)	1.50	38.10	57	53	43	28	17.6	11.5	7.5	4.9	3.2	2.2
6	5.00 (127)	3.00	76.20	401	375	340	298	250	148	62	35	18.3	13.7
	3.50 (89)	2.50	63.50	225	203	177	153	115	65	41	26	16.5	10.8
	3.00 (76)	2.00	50.80	169	152	133	114	73	37	25	16.9	10.9	7.8
	2.63 (67)	2.00	50.80	129	118	105	92	67	37	23	14.8	8.8	5.5
	6.25 (159)	4.00	101.6	693	645	591	498	335	185	115	76	46	28
	5.00 (127)	3.00	76.20	458	413	360	299	212	134	65	36	19.0	14.0
8	3.50 (89)	2.50	63.50	244	219	195	160	114	65	41	26	15.9	11.0
	2.63 (67)	2.00	50.80	141	130	115	99	67	36	23	14.8	8.6	5.9
	8.00 (203)	4.00	101.6	1015	923	819	724	604	425	191	112	70	41
	6.25 (159)	4.00	101.6	691	623	543	469	343	189	118	78	47	29
	5.00 (127)	3.00	76.20	479	431	376	296	211	133	65	36	18.9	13.9
	9.50 (241)	4.00	101.6	1407	1287	1138	958	764	533	268	158	99	58
12	7.38 (187)	4.00	101.6	937	860	758	638	481	268	142	97	65	44
	6.25 (159)	4.00	101.6	752	685	614	509	335	185	115	76	46	28

* Data above refer to the valves with unbalanced trim. Consult Valtek Sulamericana to obtain information regarding the C_v of pressure-balanced valves.

FLOW COEFFICIENTS

Flow Direction: Over the Plug

FLOW COEFFICIENTS (C_v) - QUICK-OPEN* (TABLE XVI)

VALVE SIZE (inches)	TRIM SIZE (TN)	STROKE		C _v AT PERCENT OPEN									
		in.	mm	100	90	80	70	60	50	40	30	20	10
0.5	0.50 (13)	0.75	19.05	4.8	4.6	4.4	4.1	3.8	3.5	3.1	2.4	1.40	0.74
0.75	0.71 (18)	0.75	19.05	7.6	7.5	7.5	7.4	7.3	7.3	6.4	4.9	3.0	1.72
1	0.81 (21)	0.75	19.05	11.1	11.1	11.1	11.1	10.1	10.1	8.7	6.3	3.7	1.92
1.5	1.25 (32)	1.00	25.40	30	29	29	29	28	25	20	14.1	9.0	4.9
2	1.63 (41)	1.50	38.10	50	49	49	48	47	46	39	28	15.1	8.3
3	2.63 (67)	2.00	50.80	128	127	126	126	124	109	90	64	39	22
4	3.50 (89)	2.50	63.50	223	223	220	216	211	185	153	110	68	38
6	5.00 (127)	3.00	76.20	465	465	464	462	419	361	295	221	143	76
8	6.25 (159)	4.00	101.6	728	718	708	695	683	594	480	361	223	117
10	8.00 (203)	4.00	101.6	1175	1155	1125	1095	976	836	747	542	365	190
12	9.50 (241)	4.00	101.6	1667	1617	1567	1437	1278	1108	938	737	494	246

Flow Direction: Under the Plug

FLOW COEFFICIENTS (C_v) - QUICK-OPEN* (TABLE XVII)

VALVE SIZE (inches)	TRIM SIZE (TN)	STROKE		C _v AT PERCENT OPEN									
		in.	mm	100	90	80	70	60	50	40	30	20	10
0.5	0.50 (13)	0.75	19.05	4.5	4.4	4.2	4.0	3.7	3.4	3.0	2.3	1.40	0.73
0.75	0.71 (18)	0.75	19.05	7.2	7.2	7.1	7.1	7.1	7.0	6.2	4.7	2.9	1.72
1	0.81 (21)	0.75	19.05	11.1	11.1	10.1	10.1	10.1	10.0	8.4	6.1	3.5	1.92
1.5	1.25 (32)	1.00	25.40	28	28	28	27	27	24	19	13.8	8.5	4.7
2	1.63 (41)	1.50	38.10	47	46	45	45	44	44	37	28	14.8	7.9
3	2.63 (67)	2.00	50.80	122	122	121	120	119	105	86	62	38	21
4	3.50 (89)	2.50	63.50	213	213	210	207	203	178	147	107	66	37
6	5.00 (127)	3.00	76.20	445	445	444	443	402	347	285	214	139	74
8	6.25 (159)	4.00	101.6	696	686	677	666	656	572	463	350	216	115
10	8.00 (203)	4.00	101.6	1125	1105	1075	1045	936	806	725	525	355	186
12	9.50 (241)	4.00	101.6	1586	1546	1496	1377	1227	1067	898	712	481	239

* Data above refer to the valves with unbalanced trim. Pressure-balanced trim is not available with quick-open characteristic.

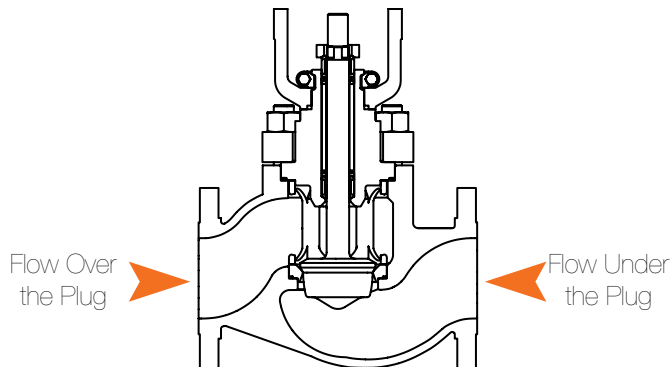

FLOW DIRECTION (FIGURE 20)

Valve Sizing

GL₅ valves are sized and selected according to rigorous criteria established by Valtek Sulamericana, based on internationally recognized standards and procedures. Consult Valtek Sulamericana to receive valuable technical support, which will help you regarding control valves sizing and application issues.

DIMENSIONS

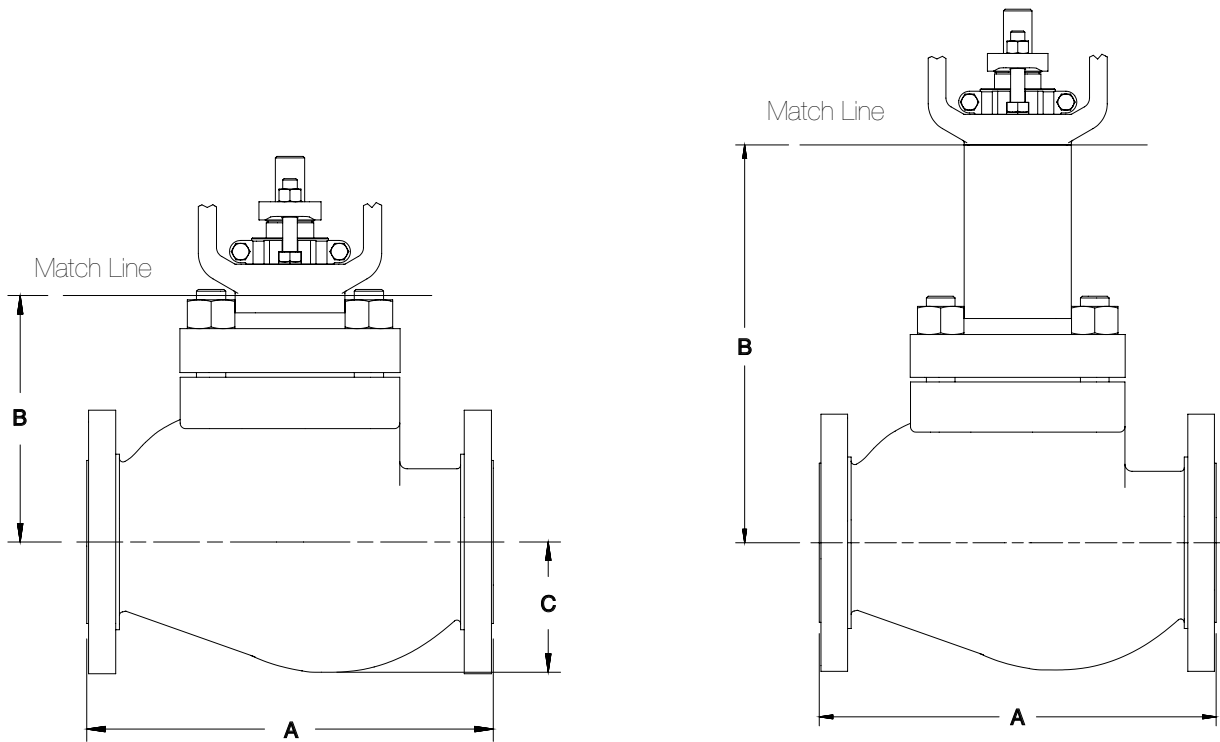

DIMENSIONS - GLOBE VALVE - ANSI CLASS 150, 300 & 600 (TABLE XVIII)

Valve Size (inches)	A								B				C		Clearance Required Above Actuator for Disassembly	
	Separable Flanges ⁽¹⁾		Integral Flanges ⁽²⁾						Standard Bonnet		Extended Bonnet					
	Class 150-600		Class 150		Class 300		Class 600									
	in.	mm	in.	mm	in.	mm	in.	mm	in.	mm	in.	mm	in.	mm		
0.5	8.5	216	7.3	184	7.5	190	8.0	203	3.8	97	8.3	212	1.5	38	2.5	64
0.75	8.5	216	7.3	184	7.6	194	8.1	206	3.8	97	8.3	212	1.5	38	2.5	64
1	8.5	216	7.3	184	7.8	197	8.3	210	3.8	97	8.3	212	1.8	44	2.5	64
1.5	9.5	241	8.8	222	9.3	235	9.9	251	5.2	132	9.7	246	2.3	59	4.0	102
2	11.5	292	10.0	254	10.5	267	11.3	286	5.4	138	9.9	252	2.3	59	4.5	114
3	14.0	356	11.8	298	12.5	318	13.3	337	6.8	172	12.3	312	3.4	86	5.8	147
4	17.0	432	13.9	353	14.5	368	15.5	394	8.4	214	13.9	354	5.2	133	7.5	190
6			17.8	451					10.1	256	15.6	395	5.5	139	10.0	254
6					18.6	473	20.0	508	12.3	311	17.8	451	5.8	146	10.0	254
8			21.4	543					12.5	318	18.0	457	7.1	180	10.9	277
8					22.4	568	24.0	610	14.4	365	19.9	505	7.5	191	11.4	290
10			26.5	673					14.1	359	19.6	498	8.4	214	11.9	302
10					27.9	708	29.6	752	14.1	359	20.6	524	8.9	227	12.1	308
12			29.0	737					14.1	359	19.6	498	9.6	243	12.6	320
12					30.5	775	32.3	819	16.3	413	22.8	578			12.6	320

⁽¹⁾ According to ANSI/ISA-75.08.07, last edition. Sizes 1/2 & 3/4-inch are not covered by this standard.

⁽²⁾ According to ANSI/ISA-75.08.01, last edition.

DIMENSIONS, ESTIMATED SHIPPING WEIGHTS

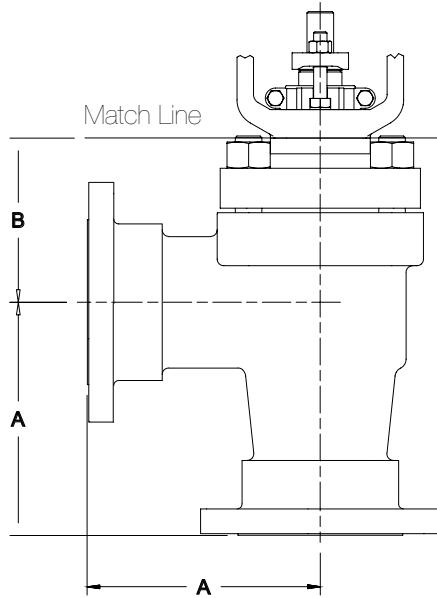

DIMENSIONS - ANGLE VALVE - CLASS 150, 300 & 600 (TABLE XIX)

Valve Size (inches)	ANSI Class	A ⁽¹⁾		B				Clearance Required Above Actuator for Disassembly	
				Standard Bonnet		Extended Bonnet			
		in.	mm	in.	mm	in.	mm	in.	mm
0.5 to 1	150-600	4.3	108	3.1	78	7.6	192	2.5	64
1.5	150-600	4.8	121	3.6	92	8.1	206	4.0	102
2	150-600	5.8	146	3.9	100	8.4	214	4.5	114
3	150-600	7.0	178	4.9	124	10.4	264	5.8	147
4	150-600	8.8	222	6.2	156	11.7	295	7.5	190
6	150	8.9	226	7.1	180	12.6	320	10.0	254
6	300-600	11.0	279	9.5	241	15.0	381	10.0	254
8	150	13.0	330	9.0	229	14.5	368	13.8	349
8	300-600	13.0	330	10.8	275	16.3	414	13.8	349

⁽¹⁾ Dimension A in accordance with Valtek Sulamericana's standards.

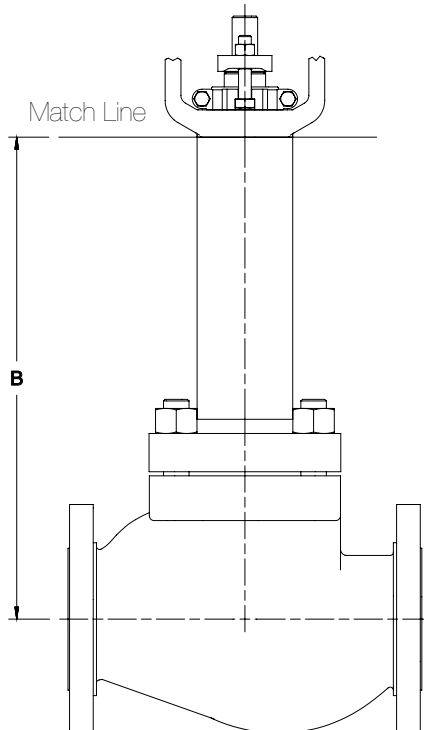

DIMENSIONS - EXTENDED BONNET FOR COLD BOX (TABLE XX)

Valve Size (inches)	ANSI Class	B					
		Standard Cold Box Extension					
		in.	mm	in.	mm	in.	mm
0.5 to 1	150-600	15.0	381	24.0	610	27.0	686
1.5	150-600	15.0	381	24.0	610	27.0	686
2	150-600	15.3	387	24.3	616	27.3	692
3	150-600	18.0	457	24.0	610	27.0	686
4	150-600	18.0	457	24.0	610	27.0	686
6	150	18.0	457	24.0	610	27.0	686

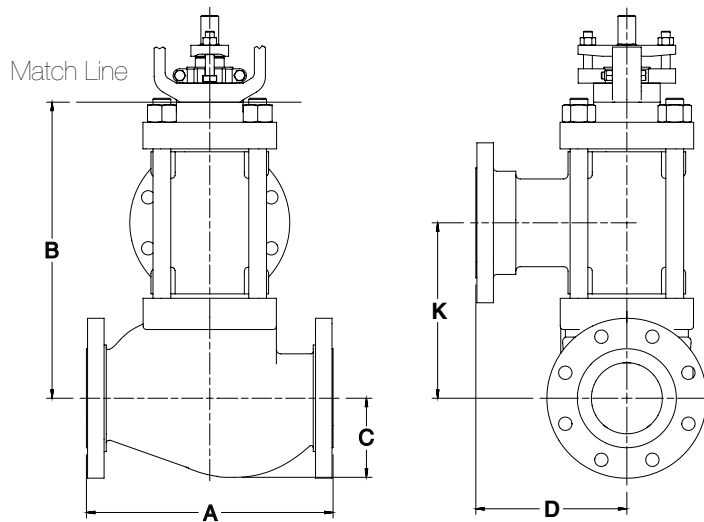

DIMENSIONS - THREE-WAY VALVE (TABLE XXI)

Valve Size (inches)	A								B				C		D		K		Clearance Required Above Actuator for Disassembly	
	Sep. Flanges ⁽¹⁾		Integral Flanges ⁽²⁾						Standard Bonnet		Extended Bonnet									
	Class 150-600		Class 150		Class 300		Class 600													
	in.	mm	in.	mm	in.	mm	in.	mm	in.	mm	in.	mm	in.	mm	in.	mm	in.	mm		
0.5	8.5	216	7.3	184	7.5	190	8.0	203	6.7	170	11.2	284	1.5	38	4.3	108	3.4	87	3.4	87
0.75	8.5	216	7.3	184	7.6	194	8.1	206	6.7	170	11.2	284	1.5	38	4.3	108	3.4	87	3.4	87
1	8.5	216	7.3	184	7.8	197	8.3	210	6.7	170	11.2	284	1.8	44	4.3	108	3.4	87	3.4	87
1.5	9.5	241	8.8	222	9.3	235	9.9	251	9.1	230	13.4	341	2.3	59	4.8	121	5.4	137	5.0	127
2	11.5	292	10.0	254	10.5	267	11.3	286	9.3	236	13.7	347	2.3	59	5.8	146	5.6	143	5.5	140
3	14.0	356	11.8	298	12.5	318	13.3	337	13.0	329	18.5	470	3.4	86	7.0	178	7.6	194	7.1	181
4	17.0	432	13.9	353	14.5	368	15.5	394	16.7	423	22.1	562	5.2	133	8.5	216	9.9	251	9.4	240
6			17.8	451					21.6	548	26.6	675	5.5	139	8.9	226	14.0	356	11.6	294
6					18.6	473	20.0	508	25.8	654	31.3	794	5.8	146	10.0	254	16.0	406	11.6	294
8			21.4	543					23.9	608	29.4	748	7.1	180	10.7	272	15.0	381	12.2	310
8					22.4	568	24.0	610	30.2	767	35.7	907	7.5	191	12.0	305	18.3	464	12.2	310

⁽¹⁾ According to ANSI/ISA-75.08.07, last edition. Sizes 1/2 & 3/4-inch are not covered by this standard.

⁽²⁾ According to ANSI/ISA-75.08.01, last edition.

ESTIMATED SHIPPING WEIGHTS* (TABLE XXII)

Valve Size (inches)	Class 150		Class 300		Class 600		Add for Extended Bonnet	
	lbs.	kg	lbs.	kg	lbs.	kg	lbs.	kg
0.5 & 0.75	40	18	40	18	40	18	5	2
1	50	23	50	23	50	23	5	2
1.5	65	30	65	30	65	30	5	2
2	75	34	75	34	75	34	5	2
3	160	73	170	77	180	82	15	7
4	240	109	250	114	265	120	20	9
6	360	163	570	259	600	272	40	18
8	590	268	790	359	830	377	65	30
10	1050	477	1405	638	1600	726	90	41
12	1278	581	1772	805	2058	935	100	46

ADDITIONAL WEIGHT FOR OVERSIZED ACTUATORS (TABLE XXIII)

Standard Original Size	Oversized Actuator Required	Add	
		lbs.	kg
25	50	30	14
50	100	90	41
100	200	125	57

* Globe-style valve equipped with standard size actuator and positioner.

Quality Management System



ISO 9001-2000

Certificate No. 311001 QM

The information and specification contained in this bulletin are considered accurate. However, they are provided only for information purposes and should not be considered as certified. Valtek Sulamericana products are continuously improved and upgraded and the specification, dimensions and information contained herein are subject to change without notice. For further information or to confirm these presented here, contact your Valtek Sulamericana representative. The specific instructions for installation, operation and maintenance of the GLS control valve are provided in Maintenance Bulletin #1.

Kalrez and Zymax are registered trademarks of E.I. Du Pont Company
Monel is a registered trademark of Special Metals.
Hastelloy C and Hastelloy B are registered trademarks of Haynes International.
Buna N and Viton A are registered trademarks of Du Pont Dow Elastomers

| Printed in Brazil |

www.valteksulamericana.com.br

Cat. Valtek Sulamericana GLS - 04/2007E - PN-9810002