



**FULL BORE BALL  
CONTROL VALVE**

**TBV<sup>®</sup>**



# INTRODUCTION

The full bore TBV ball control valve was designed to offer minimum resistance to the fluid passage, providing high flow capacity, high rangeability, bidirectional sealing and an inherent equal percentage control characteristic.

Developed for demanding applications in the chemical, petrochemical, pulp & paper and oil & gas industries, the TBV valve can operate with clean, fibrous or contaminated fluids maintaining its remarkable sealing capacity even after several years of use.

Manufactured in a single unit, the TBV ball/shaft assembly assures a smooth, stable and precise operation of the valve, even under high differential pressures. Since the valve body is symmetrically split, the valve maintenance is simplified and reinstallation of the ball/shaft assembly is done safely, even for larger sizes.

Available with flanged connections from 1 to 36 inches, the TBV valve can operate with temperatures from -20 to 842°F (-28 to 450°C) and pressures corresponding to ANSI 150, 300 and 600 classes. Valve bodies can be manufactured in carbon steel, stainless steel or with special alloys (upon request).

The available options for seats, trim materials and ball with full or reduced passage area, among other features, allow the TBV valve to meet the most varied needs of the continuous process industries, either in throttling control or in on-off services.

Its advanced design characteristics, its sturdiness, reliability and low operational cost, make the TBV one of the main current benchmarks for ball type control valves.

**TBV VALVE – BODY SUB-ASSEMBLY (FIGURE 1)**

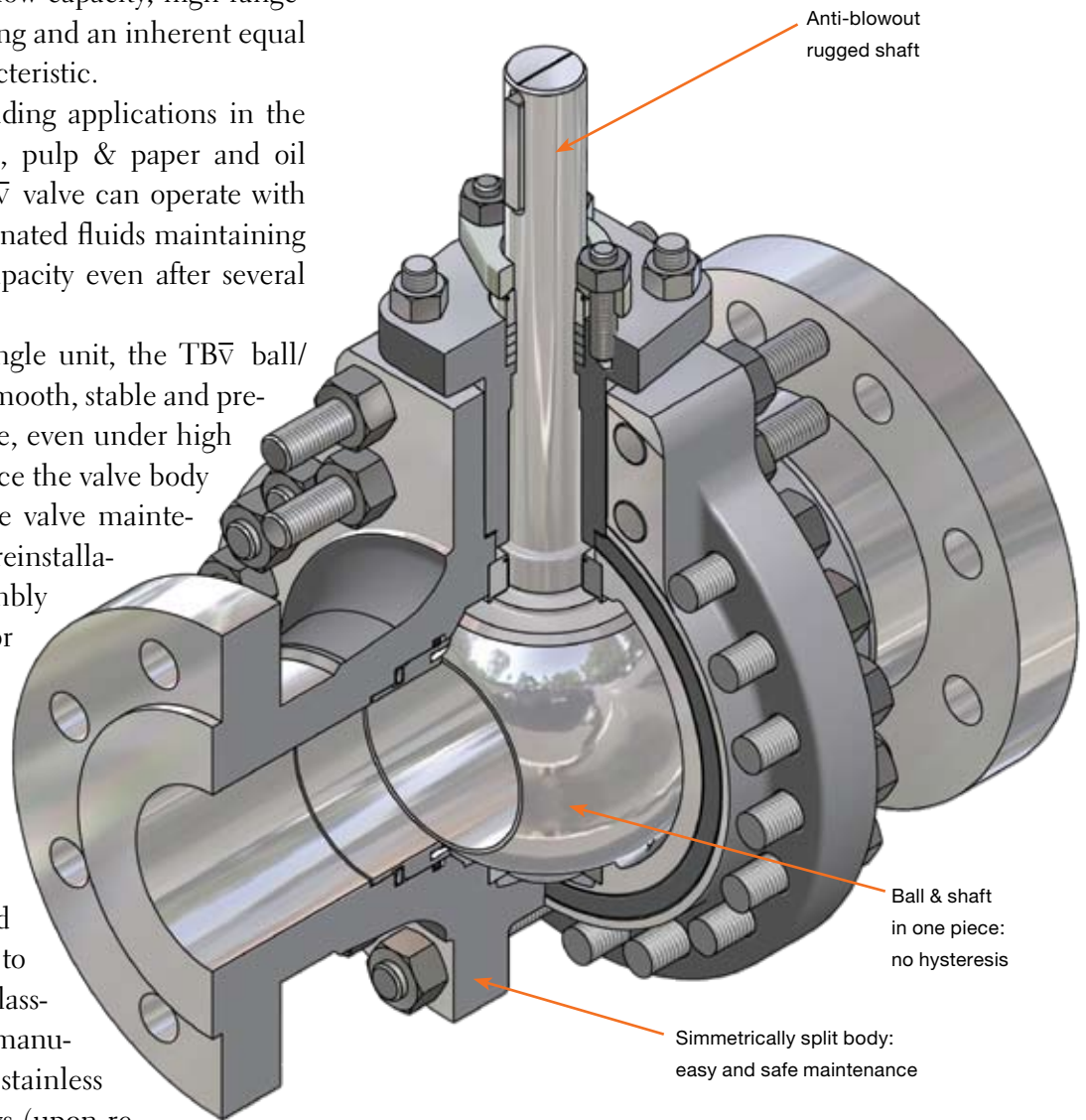

---

### Typical Rangeability from 100:1 to 300:1<sup>(1)</sup>

---

#### Shutoff

**Metal Seat:** Valtek Sulamericana Standard<sup>(2)</sup>  
ANSI Class V  
ISO 5208 – Rate D<sup>(2)</sup>

**Soft Seat:** ANSI Class VI  
API-598  
ISO 5208 – Rate A

---

<sup>(1)</sup> Depending on valve size.

<sup>(2)</sup> See details in table on page 5.

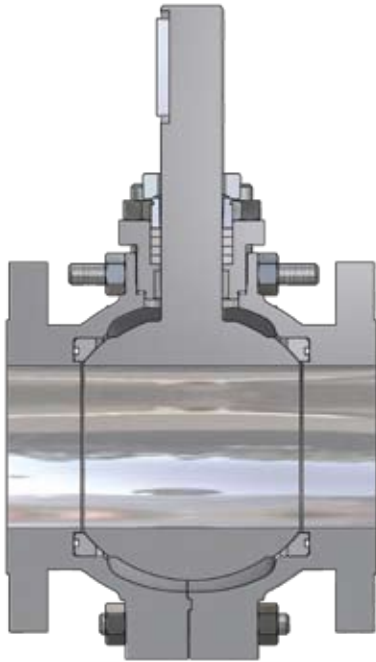

**PENDULAR ASSEMBLY (FIGURE 2)**

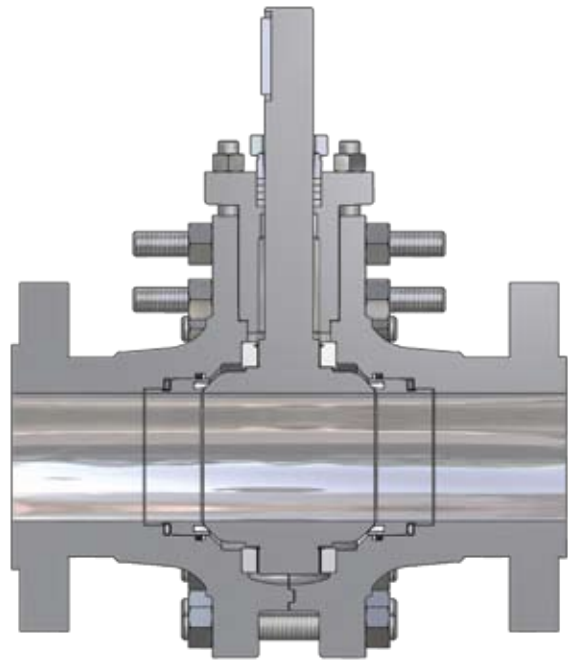

**TRUNNION ASSEMBLY (FIGURE 3)**

## Reliability

The connection of the male and female halves of the TBV valve split body is done by means of a flanged connection, using strong fastening elements with the appropriate dimensions and quantities. With this body rigid assembly the TBV valve is immune to the effect caused by piping stress, eliminating leakage risks.

To assure low operating torques, the assembly of the ball may be pendular or trunnion type, depending on the size and pressure class of the valve. On pendular type assembly versions, the valve ball is supported by the seats, while on trunnion assembly configurations the ball is supported by two large surface bearings, which assure excellent stability of the shaft/ball assembly, as well as remarkable smooth operation and precise positioning. On trunnion assembly versions, an advanced spring system press the seats against the ball, contributing to the sealing and assuring the relief of the ball cavity in case of overpressure. On pendular type valves equipped with metal seats, the ball displacement itself assures the sealing and the relief of the cavity<sup>(1)</sup>.

<sup>(1)</sup> In services with condensate, liquefied gas, steam or other applications where there is a risk of overpressure, valves with pendular type assembly equipped with soft seats must be provided with an upstream relief hole.

The TBV valve features a pressure-assisted sealing effect, i.e, in the pendular type version, the upstream pressure pushes the ball against the seat, while in the trunnion assembly version, the fluid force actuating against the upstream seat adds to the spring force to assure an excellent sealing capacity, even at low pressures.

The metal and soft seat options of the TBV valve always allow choosing the best option for each application. The smooth movement of the ball and the wide contact surfaces of the seats provide the TBV valves sealing with a substantial increase on its operating life, either in throttling control or in on-off services.

The TBV valve is equipped with a bonnet with packing box independent from the body, which makes the valve reliable to operate with different kind of fluids over a wide range of operating temperatures.

All these characteristics, together with the use of: spring-cylinder actuators, with proven lifetime longer than a million of cycles; HPP1500 analog or HPP3000 and HPP3500 digital positioners, which provide an accurate and refined process control; and large packing box allowing the use of several packing options, make the TBV one of the most advanced, precise and modern ball valve in the worldwide market.

## Construction

As the construction shape and the sealing principles, the assembly of the ball of the TBV valve may be pendular or trunnion type depending on the size and the pressure class.

In larger sizes and pressure classes, using the trunnion type assembly allows that the required values for the valve actuating torque are maintained within relatively low values.

**BALL ASSEMBLY & END CONNECTIONS (TABLE I)**

VALVE SIZE (INCHES)	ANSI CLASS	BALL ASSEMBLY STYLE	END CONNECTIONS
1 & 1.5	150, 300 & 600	Pendular	RF Flanges, RTJ <sup>(1)(2)</sup>
2 & 3	150 & 300	Pendular	RF Flanges, RTJ <sup>(1)(2)</sup>
	600	Trunnion	RF Flanges, RTJ <sup>(1)(2)</sup>
4	150	Pendular	RF Flanges <sup>(2)</sup>
	300 & 600	Trunnion	RF Flanges, RTJ <sup>(1)(2)</sup>
6 to 24	150, 300 & 600	Trunnion	RF Flanges, RTJ <sup>(1)(2)</sup>
28 to 36	150 & 300	Trunnion	RF Flanges, RTJ <sup>(1)(2)</sup>

<sup>1)</sup> RTJ flanges available for ANSI 300 & 600 Classes.<sup>2)</sup> Other types of flanged connections available upon request.

## End Connections

The Connection of TBV valve to the process is done through raised face integral flanges which, in order to obtain better sealing to the adjacent piping flanges are machined with spiral grooves. Optionally, the TBV valve flanged connections may be supplied with other types of surface finishing, such as: smooth finish, flat face and RTJ.

## Body Joint

The assembly of the two symmetrical body halves of the TBV valve is done using studs and nuts, according to the material table below:

**BODY BOLTING MATERIAL (TABLE II)**

BODY BOLTING	VALVE BODY MATERIAL	
	CARBON STEEL ASTM A216 GR. WCB <sup>(2)</sup>	STAINLESS STEEL ASTM A351 GR. CF8M
Studs	ASTM A193 Gr. B7 <sup>(3)</sup>	ASTM A193 Gr. B8 <sup>(4)</sup>
Nuts	ASTM A194 Gr. 2H <sup>(3)</sup>	ASTM A194 Gr. 8 <sup>(4)</sup>
Drain Plug <sup>(1)</sup>	316 SS	316 SS

<sup>1)</sup> Normally used only on trunnion mounted valves. <sup>2)</sup> Optionally may be supplied with stainless steel bolting. <sup>3)</sup> B7/2H bolting is recommended for temperatures from -20 to 800°F (-28 to 426°C). <sup>4)</sup> B8/8 bolting is recommended for temperatures from -425 to 1500°F (-253 to 815°C). <sup>5)</sup> The temperature limits above are valid for maximum allowable pressures according to ANSI B16.34 (last edition).

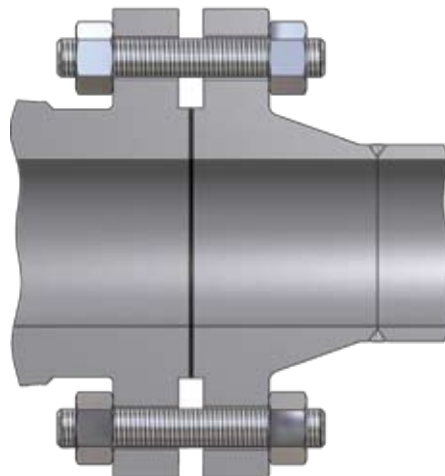

**RF INTEGRAL FLANGE (FIGURE 4)**

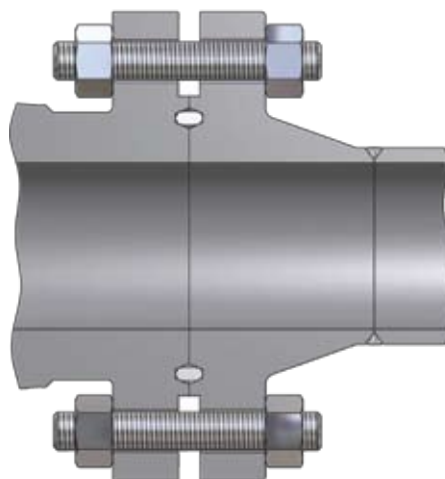

**RTJ INTEGRAL FLANGE (FIGURE 5)**

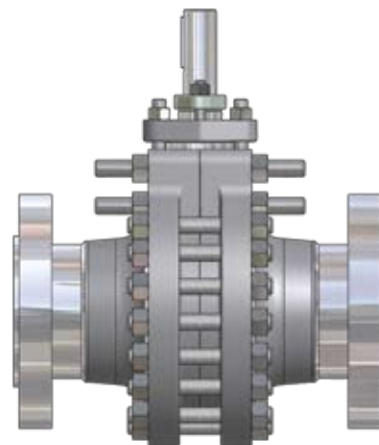

**BODY JOINT BOLTING (FIGURE 6)**

**Ball and Shaft**

The ball and the oversized shaft of the TBV valve are cast and machined in a single unit, assuring excellent concentricity to the assembly and causes the valve to operate in a smooth way, presenting great positioning precision and the absence of hysteresis. The TBV valve standard ball is solid, with full and straight passage to assure high nominal CV's with minimum flow turbulence, and allows cleaning of the piping with the valve installed.

With permanent contact with the seats, the ball of the TBV valve is usually manufactured in 316 stainless steel. On versions equipped with metal seats, the ball receives a layer of hard chrome to match the surface hardness and facilitate the relative sliding of the parts. Under throttling control, the ball in the partially open position carries out the pressure drop in two stages, which reduces the chances of cavitation.

The robust shaft is able to withstand easily the ball actuating torque.

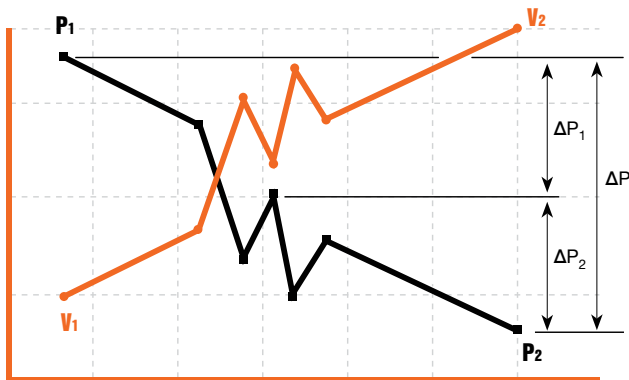

**PRESSURE AND VELOCITY PROFILES (FIGURE 7)**  
(with pressure drop in two stages)

**LEAKAGE CLASS (TABLE III)**

SEAT TYPE	LEAKAGE CLASS
Soft	Class VI (ANSI B16.104/FCI-70.2)
	API-598
	ISO-5208, rate A
Metal	10% of Class IV (ANSI B16.104/FCI-70.2) <sup>(1)</sup>
	Class V (ANSI B16.104/FCI-70.2)
	ISO-5208, rate D <sup>(2)</sup>

<sup>(1)</sup> Standard Valtek Sulamericana for valves equipped with metal seats.

<sup>(2)</sup> Contact factory for rates B & C.

**Options:**

- »»» Bonnet extension for high temperatures;
- »»» Special cleaning;
- »»» Pendular ball with upstream hole for cavity relief;
- »»» Drain plug for pendular mounted valves;
- »»» Flow passage with special coatings for abrasive/ erosive applications;
- »»» Fire-Safe version;
- »»» NACE MR-01.75 version (upon request);
- »»» Double block and bleed version equipped with bleed ball valve for cavity drain;
- »»» Anti-static packing for valves equipped with soft seats;
- »»» Ball and seats manufactured with special materials or with special coatings.

**BALL & SEAT MATERIALS (TABLE IV)**

MATERIALS	BALL	SEATS
Standard	ASTM A351 Gr. CF8M unplated	PTFE + 25% of carbon
	ASTM A351 Gr. CF8M with hard Chrome coating	ASTM A351 Gr. CF3M with Alloy #6 overlay
Special	ASTM A351 Gr. CF8M with Alloy #6 overlay	ASTM A351 Gr. CF3M with Alloy #12 overlay
	ASTM A351 Gr. CF8M with carbide coating	ASTM A351 Gr. CF3M with carbide coating
	ASTM A351 Gr. CF8M with nickel-boron coating	ASTM A351 Gr. CF3M with nickel-boron coating

**DESIGN STANDARDS (TABLE V)**

VALVE BODY	ANSI B16.34
VALVE BODY JOINT	ASME VIII, Div. 1, Appendix 2
FLANGES	ANSI B16.5
FACE-TO-FACE	ANSI B16.10 (long pattern) <sup>(1)</sup>

<sup>(1)</sup> For sizes 1 and 1.5 inch (Cl.150), the face-to-face dimensions are in accordance with Valtek Sulamericana's standards.

# MATERIALS OF CONSTRUCTION

**STANDARD MATERIALS OF CONSTRUCTION: CARBON STEEL SUB-ASSEMBLY <sup>(1)</sup> (TABLE VI)**

ITEM	MATERIAL CLASSIFICATION	SPECIFICATION		
		ASTM CODE (AMS No.)	UNS CODE	HARDNESS Rc
<b>Body (male &amp; female)</b>	Carbon Steel (Casting)	A216 Gr WCB	J 03002	
<b>Ball &amp; Shaft</b>	316 (Casting)	A351 Gr CF8M	J 92900	
	316 (Casting), Chrome Pltd.	A351 Gr CF8M	J 92900	
<b>Metal Seat</b>	316L / Alloy #6	A479 Gr 316L / AMS 5387 <sup>(6)</sup>	S 31603 / R 30006	40-42
<b>Soft Seat</b>	316 <sup>(3)</sup> / PTFE + 25%C	A479 Gr 316 / PTFE+25%C <sup>(7)</sup>	S 31600	
<b>Bonnet</b>	Carbon Steel (Casting)	A216 Gr WCB <sup>(8)</sup>	J 03002	
<b>Bearings <sup>(2)</sup></b>	316 / PTFE <sup>(4)</sup>	A479 Gr 316 / PTFE	S 31600	
	Alloy #6 <sup>(5)</sup>	AMS 5387	R 30006	40-42
<b>Seat O-Ring <sup>(2)</sup></b>	Viton-A			
<b>Seat Back-up Ring <sup>(2)</sup></b>	PTFE			
<b>Seat Spring <sup>(2)</sup></b>	Inconel X-750		N 07750	
<b>Gland Flange</b>	316 (Casting)	A351 Gr CF8M	J 92900	
<b>Packing Follower</b>	316 (Bar)	A479 Gr 316	S 31600	
<b>Shaft Key</b>	Carbon Steel SAE 1045		G 10450	

**STANDARD MATERIALS OF CONSTRUCTION: STAINLESS STEEL SUB-ASSEMBLY <sup>(1)</sup> (TABLE VII)**

ITEM	MATERIAL CLASSIFICATION	SPECIFICATION		
		ASTM CODE (AMS No.)	UNS CODE	HARDNESS Rc
<b>Body (male &amp; female)</b>	316 (Casting)	A351 Gr CF8M	J 92900	
<b>Ball &amp; Shaft</b>	316 (Casting)	A351 Gr CF8M	J 92900	
	316 (Casting), Chrome Pltd.	A351 Gr CF8M	J 92900	
<b>Metal Seat</b>	316L / Alloy #6	A479 Gr 316L / AMS 5387 <sup>(6)</sup>	S 31603 / R 30006	40-42
<b>Soft Seat</b>	316 <sup>(3)</sup> / PTFE + 25%C	A479 Gr 316 / PTFE+25%C <sup>(7)</sup>	S 31600	
<b>Bonnet</b>	316 (Casting)	A351 Gr CF8M <sup>(8)</sup>	J 92900	
<b>Bearings <sup>(2)</sup></b>	316 / PTFE <sup>(4)</sup>	A479 Gr 316 / PTFE	S 31600	
	Alloy #6 <sup>(5)</sup>	AMS 5387	R 30006	40-42
<b>Seat O-Ring <sup>(2)</sup></b>	Viton-A			
<b>Seat Back-up Ring <sup>(2)</sup></b>	PTFE			
<b>Seat Spring <sup>(2)</sup></b>	Inconel X-750		N 07750	
<b>Gland Flange</b>	316 (Casting)	A351 Gr CF8M	J 92900	
<b>Packing Follower</b>	316 (Bar)	A479 Gr 316	S 31600	
<b>Shaft Key</b>	Carbon Steel SAE 1045		G 10450	

<sup>(1)</sup> Valid for standard construction. Consult Valtek Sulamericana for versions equipped with RS-HT seats and fire-safe construction.

<sup>(2)</sup> Items normally applied only to the valves with trunnion assembly.

<sup>(3)</sup> The soft seat of the pendular valve does not use the 316 SS retainer.

<sup>(4)</sup> Comprised by a PTFE insert with 316 SS screen, assembled on a 316 SS retainer.

<sup>(5)</sup> Normally used on valves equipped with RS-HT seats for high temperature applications.

<sup>(6)</sup> On sizes 8 inches and smaller, metal seats are manufactured in investment casting Alloy #6 (UNS R30006).

<sup>(7)</sup> On sizes from 3 to 8 inches, the soft seat retainers are manufactured in investment casting stainless steel (ASTM A351 Gr. CF8M).

<sup>(8)</sup> Manufactured from bars for sizes 6 inches and smaller.

**TEMPERATURE AND PRESSURE LIMITS FOR VALVE BODIES - ANSI B16.34 (TABLE VIII)**

MATERIAL	CLASS	TEMPERATURE		PRESSURE	
		°F	°C	PSI	BAR
<b>Carbon Steel ASTM A216 Gr. WCB<sup>(1)</sup></b>	<b>ANSI 150</b>	-20 to 100	-29 to 38	285	19.7
		200	93	260	17.9
		300	149	230	15.9
		400	204	200	13.8
		500	260	170	11.7
		600	316	140	9.7
		700	371	110	7.6
		800	426	80	5.5
	850	454	65	4.4	
	<b>ANSI 300</b>	-20 to 100	-29 to 38	740	51.0
		200	93	675	46.5
		300	149	655	45.2
		400	204	635	43.8
		500	260	600	41.4
		600	316	550	37.9
		700	371	535	36.9
		800	426	410	28.2
	850	454	270	18.6	
	<b>ANSI 600</b>	-20 to 100	-29 to 38	1480	102.0
		200	93	1350	93.1
		300	149	1315	90.6
		400	204	1270	87.5
		500	260	1200	82.7
		600	316	1095	75.5
700		371	1065	73.4	
800		426	825	56.8	
850	454	535	36.8		
<b>Stainless Steel ASTM A351 Gr. CF8M</b>	<b>ANSI 150</b>	-20 to 100	-29 to 38	275	19.0
		200	93	235	16.2
		300	149	215	14.8
		400	204	195	13.4
		500	260	170	11.7
		600	316	140	9.7
		700	371	110	7.6
		800	426	80	5.5
	850	454	65	4.4	
	<b>ANSI 300</b>	-20 to 100	-29 to 38	720	49.7
		200	93	620	42.8
		300	149	560	39.4
		400	204	515	35.5
		500	260	480	33.1
		600	316	450	31.0
		700	371	430	29.7
		800	426	420	28.9
	850	454	420	28.9	
	<b>ANSI 600</b>	-20 to 100	-29 to 38	1440	99.3
		200	93	1240	85.5
		300	149	1120	77.2
		400	204	1025	70.6
		500	260	955	65.8
		600	316	900	62.0
700		371	870	60.0	
800		426	845	58.2	
850	454	835	57.5		

(1) Permissible, but not recommended for prolonged usage above 800°F (426°C).

# SEATING

## Pendular Valves

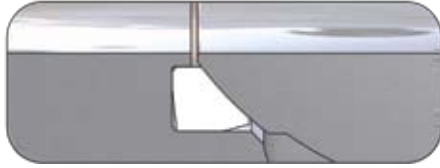

**SS TYPE SOFT SEAT (FIGURE 8)**

These seats are used with non-abrasive fluids at moderate operating  $\Delta P$ 's<sup>(1)</sup>. The seat is comprised of one PTFE ring with 25% of carbon, and a fire-safe construction variant is available as optional.

»» Temperature range: -20 to 392°F (-28 to 200°C)

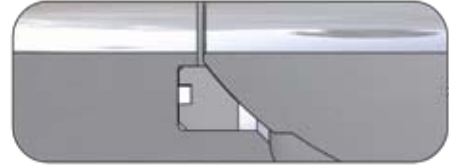

**RS TYPE METAL SEAT (FIGURE 9)**

This seat is used in cases where the operating  $\Delta P$ <sup>(1)</sup> or the presence of abrasive particles restricts the use of soft seats. The seat is comprised of one solid Alloy #6 ring assembled with a backing gasket.

»» Temperature range: -20 to 392°F (-28 to 200°C) with PTFE gasket or -20 to 842°F (-28 to 450°C) with graphite gasket.

## Trunnion Valves

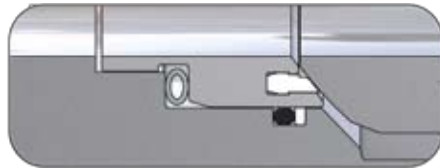

**SS TYPE SOFT SEAT (FIGURE 10)**

These seats are used with non-abrasive fluids at moderate operating  $\Delta P$ 's<sup>(1)</sup>. The seat is comprised of one 316 SS ring with a PTFE insert with 25% of carbon, and a fire-safe construction variant, which uses an additional graphite seal between the seat and the body, is available as optional.

»» Temperature range: -20 to 392°F (-28 to 200°C)

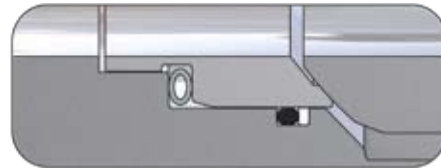

**RS TYPE METAL SEAT (FIGURE 11)**

These seats are used in cases where the operating  $\Delta P$ <sup>(1)</sup> or the presence of abrasive particles restricts the use of soft seats. The seat is comprised of one 316L SS ring with Alloy #6 overlay on seating surface.

»» Temperature range: -20 to 392°F (-28 to 200°C)

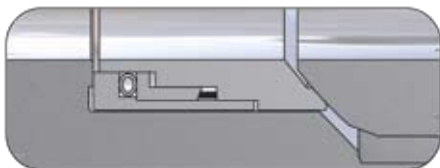

**RS-HT TYPE METAL SEAT<sup>(2)</sup> (FIGURE 12)**

RS-HT seats for high temperature applications use graphite seals replacing the Viton O-Rings and the PTFE back-up rings used on other versions, making this construction inherently fire-safe. Likewise the RS seat, the RS-HT seat is manufactured with A 316L SS ring with Alloy #6 overlay.

»» Temperature range: -20 to 842°F (-28 to 450°C)

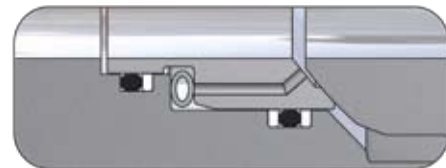

**RSC TYPE METAL SEAT (FIGURE 13)**

Used with clean fluids in demanding applications. Changing the contact forces balance between the ball and seats, this arrangement provides a friction reduction which increases the lifetime of the sealing and provides a smoother and more precise control. The RSC seat is comprised of one 316L SS ring with Alloy #6 overlay.

»» Temperature range: -20 to 392°F (-28 to 200°C)

(1) See recommended limits for operating pressure drop ( $\Delta P$ ) on table IX. (2) Available only on sizes from 2 to 24 inches.



**MAXIMUM ALLOWABLE PRESSURE DROP - SEATS (TABLE IX) <sup>(1)(2)</sup>**

**SEAT TYPE AND MATERIAL: SOFT SEAT (SS) - PTFE WITH 25% OF CARBON <sup>(3)</sup>**

ANSI Class	Valve Size (inches)	Temperature Range									
		°F	°C	°F	°C	°F	°C	°F	°C	°F	°C
		-20 to 100	-29 to 38	122	50	212	100	302	150	392	200
		Maximum Shutoff Drop / Maximum Operating $\Delta P$ in Throttling Control <sup>(4)(5)</sup>									
		PSI	Bar	PSI	Bar	PSI	Bar	PSI	Bar	PSI	Bar
150	1 to 2	276 / (102)	19 / (7)	261 / (87)	18 / (6)	232 / (58)	16 / (4)	203 / (44)	14 / (3)	189 / (0)	13 / (0)
	3	276 / (87)	19 / (6)	261 / (58)	18 / (4)	232 / (44)	16 / (3)	203 / (29)	14 / (2)	189 / (0)	13 / (0)
	4	276 / (73)	19 / (5)	261 / (58)	18 / (4)	232 / (44)	16 / (3)	203 / (29)	14 / (2)	189 / (0)	13 / (0)
	6 to 16	276 / (145)	19 / (10)	261 / (116)	18 / (8)	232 / (87)	16 / (6)	203 / (58)	14 / (4)	189 / (0)	13 / (0)
	18 to 24	276 / (145)	19 / (10)	261 / (116)	18 / (8)	232 / (87)	16 / (6)	203 / (58)	14 / (4)	189 / (0)	13 / (0)
300	1 to 2	725 / (102)	50 / (7)	696 / (87)	48 / (6)	609 / (58)	42 / (4)	551 / (44)	38 / (3)	508 / (0)	35 / (0)
	3	725 / (87)	50 / (6)	696 / (58)	48 / (4)	609 / (44)	42 / (3)	551 / (29)	38 / (2)	508 / (0)	35 / (0)
	4 to 16	725 / (145)	50 / (10)	696 / (116)	48 / (8)	609 / (87)	42 / (6)	551 / (58)	38 / (4)	508 / (0)	35 / (0)
	18 to 24	725 / (145)	50 / (10)	696 / (116)	48 / (8)	609 / (87)	42 / (6)	551 / (58)	38 / (4)	508 / (0)	35 / (0)
600	1 & 1.5	725 / (102)	50 / (7)	696 / (87)	48 / (6)	609 / (58)	42 / (4)	551 / (44)	38 / (3)	508 / (0)	35 / (0)
	2 to 24	1450 / (145)	100 / (10)	1392 / (116)	96 / (8)	1218 / (87)	84 / (6)	1117 / (58)	77 / (4)	870 / (0)	60 / (0)

**SEAT TYPE AND MATERIAL: METAL SEAT (RS & RSC) - 316L SS/ALLOY #6 <sup>(6)(7)</sup>**

ANSI Class	Valve Size (inches)	Temperature Range									
		°F	°C	°F	°C	°F	°C	°F	°C	°F	°C
		-20 to 100	-29 to 38	122	50	212	100	302	150	392	200
		Maximum Shutoff Drop / Maximum Operating $\Delta P$ in Throttling Control <sup>(5)</sup>									
		PSI	Bar	PSI	Bar	PSI	Bar	PSI	Bar	PSI	Bar
150	1 to 2	276 / (218)	19 / (15)	261 / (203)	18 / (14)	232 / (174)	16 / (12)	203 / (160)	14 / (11)	189 / (145)	13 / (10)
	3	276 / (174)	19 / (12)	261 / (160)	18 / (11)	232 / (145)	16 / (10)	203 / (131)	14 / (9)	189 / (116)	13 / (8)
	4	276 / (145)	19 / (10)	261 / (131)	18 / (9)	232 / (116)	16 / (8)	203 / (102)	14 / (7)	189 / (102)	13 / (7)
	6 to 16	276 / (276)	19 / (19)	261 / (261)	18 / (18)	232 / (232)	16 / (16)	203 / (203)	14 / (14)	189 / (189)	13 / (13)
	18 to 24	261 / (261)	18 / (18)	247 / (247)	17 / (17)	218 / (218)	15 / (15)	189 / (189)	13 / (13)	174 / (174)	12 / (12)
300	1 to 2	363 / (218)	25 / (15)	348 / (203)	24 / (14)	305 / (174)	21 / (12)	276 / (160)	19 / (11)	247 / (145)	17 / (10)
	3	363 / (174)	25 / (12)	348 / (160)	24 / (11)	305 / (145)	21 / (10)	276 / (131)	19 / (9)	247 / (116)	17 / (8)
	4 to 16	725 / (508)	50 / (35)	696 / (479)	48 / (33)	609 / (435)	42 / (30)	551 / (392)	38 / (27)	508 / (363)	35 / (25)
	18 to 24	595 / (508)	41 / (35)	566 / (479)	39 / (33)	493 / (435)	34 / (30)	450 / (392)	31 / (27)	421 / (363)	29 / (25)
600	1 & 1.5	522 / (218)	36 / (15)	493 / (203)	34 / (14)	435 / (174)	30 / (12)	392 / (160)	27 / (11)	363 / (145)	25 / (10)
	2 to 24	1450 / (508)	100 / (35)	1392 / (479)	96 / (33)	1218 / (435)	84 / (30)	1117 / (392)	77 / (27)	1030 / (363)	71 / (25)

<sup>(1)</sup> Body rating shall not be exceeded.

<sup>(2)</sup> For trunnion mounted valves, the values shown above consider the use of 316 SS/PTFE bearings.

<sup>(3)</sup> Used with stainless steel ball (ASTM A351 Gr. CF8M), unplated.

<sup>(4)</sup> PTFE with 25% of carbon seats are not recommended for throttling services at operating temperatures higher than 302°F (150°C).

<sup>(5)</sup> The values of  $\Delta P$  above are valid for clean liquids and gases. If the fluid contains abrasive particles, the values above must be evaluated over again.

<sup>(6)</sup> Used with stainless steel (ASTM A351 Gr. CF8M)/hard chrome plated balls.

<sup>(7)</sup> For valves equipped with RS-HT seats for high temperatures, Alloy #6 bearings or special combination of materials for seats and ball, consult Valtek Sulamericana for the allowable temperature and pressure limits.

## Gaskets

The TB $\bar{v}$  valve standard versions use bonnet, body and seat backing (where applicable) gaskets made with PTFE, which present excellent sealing capacity and is chemically compatible with most of the process fluids.

For operating temperatures higher than 392°F (200°C) it is recommended to use graphite gaskets, which is the standard material used on gaskets of valves equipped with RS-HT seats for high temperatures and on TB $\bar{v}$  valve versions with fire-safe construction.

Regarding the pressure, the PTFE gaskets may resist the maximum differential pressures indicated on table IX, both for versions equipped with soft seats and for versions equipped with metal seats. In case of graphite gaskets, the recommended pressure limits are the same pressure limits valid for the valve body.

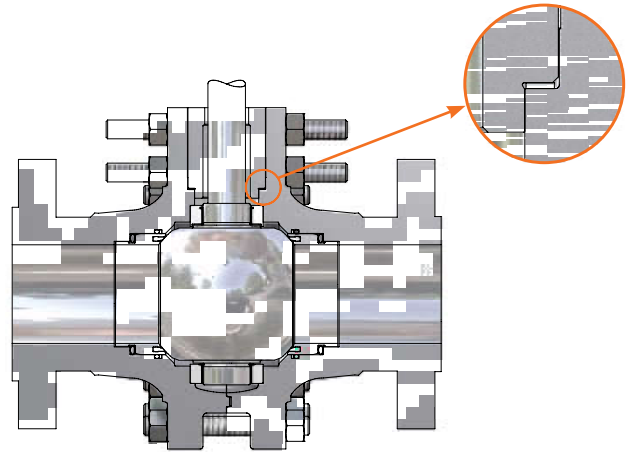

**TB $\bar{v}$  – DETAILS OF GASKETS (FIGURE 14)**

**GASKET TEMPERATURE LIMITS (TABLE X)**

GASKET MATERIAL	TEMPERATURE LIMITS	
	°F	°C
PTFE	-20 to 392	-28 to 200
Graphite	-20 to 842 <sup>(1)</sup>	-28 to 450 <sup>(1)</sup>

<sup>(1)</sup> For TB $\bar{v}$  valves equipped with RS-HT seats.

## Bearings

The TB $\bar{v}$  standard bearing for trunnion type assembly is comprised by one retainer made with 316 stainless steel and one PTFE insert reinforced internally with a 316 stainless steel screen, whose pressure limits are the same indicated on table IX.

Above 392°F (200°C) it is recommended to use bearings made with Alloy #6, which are supplied as standard item on valves equipped with RS-HT seats.

Although the Alloy #6 bearings are an excellent option for high temperature applications, the use of this material below 392°F (200°C) should be avoided, considering that the higher friction that this kind of material causes, restricts the use of the TB $\bar{v}$  valve trim to differential pressures lower than those normally accepted for standard bearings, particularly on larger sizes and/or on valves that operate with non-lubricant fluids, as gases. Using Alloy #6 bearings requires those areas of the shaft contacting the upper and the lower bearing to receive also an Alloy #6 overlay.

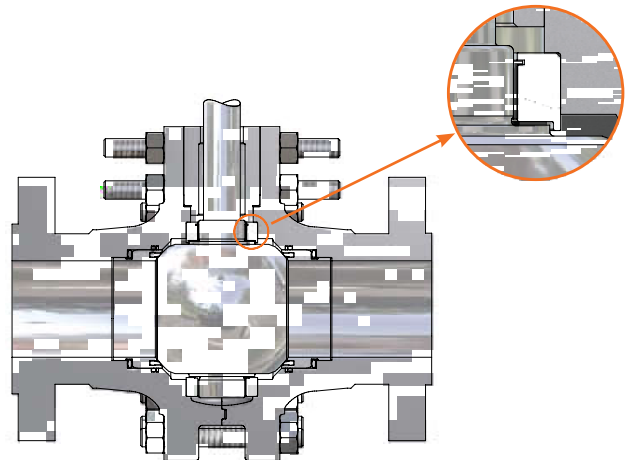

**TB $\bar{v}$  – DETAILS OF BEARINGS (FIGURE 15)**

**BEARING TEMPERATURE LIMITS (TABLE XI)**

BEARING MATERIAL	TEMPERATURE LIMITS	
	°F	°C
316 SS/PTFE	-20 to 392	-28 to 200
Alloy #6	-20 to 842 <sup>(1)</sup>	-28 to 450 <sup>(1)</sup>

<sup>(1)</sup> For TB $\bar{v}$  valves equipped with RS-HT seats.

## PACKING

DIFFERENTLY FROM THE TRADITIONAL BALL VALVES, THE TB $\bar{v}$  BALL VALVE HAS A DEEP PACKING BOX WITH AN EXCELLENT FINISH OF INTERNAL SURFACES, WHICH PROVIDES A LONGER OPERATING LIFE FOR THE WHOLE PACKING SET.

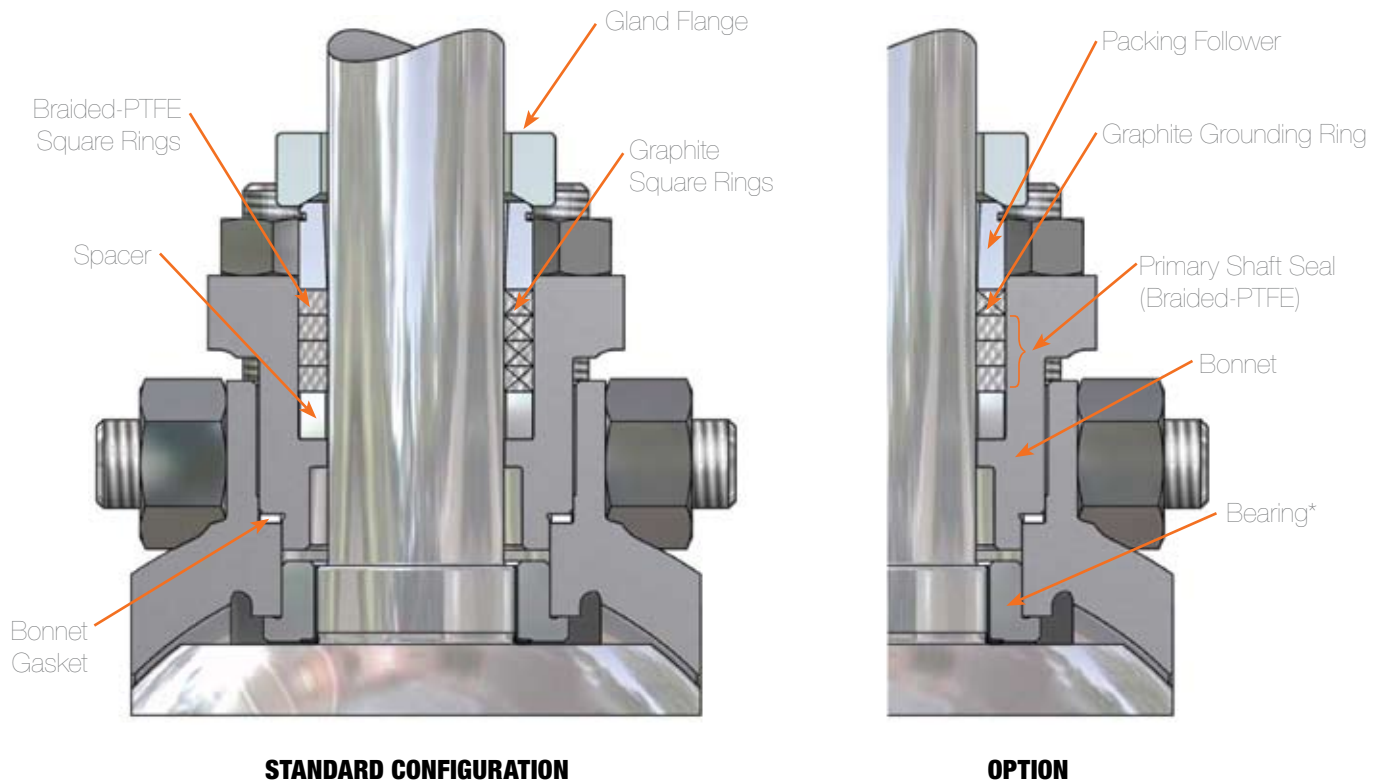

**TYPICAL PACKING ARRANGEMENTS OF TB $\bar{v}$  BALL VALVE (FIGURE 16)**

### Standard Packing

The standard packing of the TB $\bar{v}$  valve is comprised by molded braided-PTFE square rings which may be used with temperatures up to 500°F (260°C).

### High Temperature Packing

The high temperature packing of TB $\bar{v}$  valve is comprised by molded graphite square rings that can be used with temperatures up to 842°F (450°C) on TB $\bar{v}$  valves equipped

with RS-HT seats. This packing material is standard also for the fire-safe versions.

### Anti-Static Packing

This packing option is normally used when it is necessary to assure electrical continuity on valves equipped with soft seats and primary sealing on the shaft with PTFE packing rings. In this case, a graphite ring is assembled on the top of the packing set which do not enter in direct contact with the operating fluid.

\* Applicable only to trunnion valves.

# FLOW COEFFICIENTS

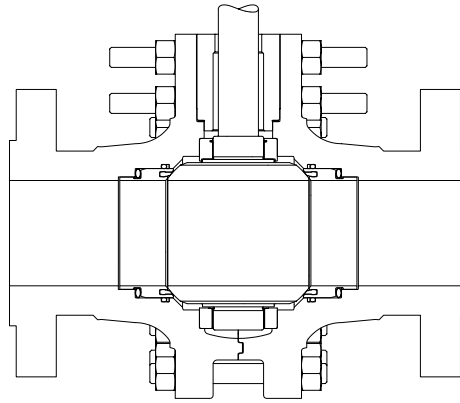

**FLOW COEFFICIENTS (C<sub>v</sub>) - (TABLE XII)**

Valve Size (inches)	Opening Angle (Degrees)								
	90	80	70	60	50	40	30	20	10
1	107	45	25	15.5	10.0	6.3	3.6	1.8	0.8
1.5	247	119	68	39	24	14.7	8.4	4.2	1.8
2	475	211	110	61	36	22	12.5	6.4	2.8
3	1170	519	272	151	92	60	35	18.4	6.9
4	2110	935	491	267	154	100	59	31	11.4
6	5090	2270	1191	641	356	231	137	71	26
8	9320	4172	2190	1171	633	410	244	127	47
10	15175	6727	3531	1880	999	645	383	199	74
12	22410	9935	5215	2759	1434	928	549	287	107
14	28320	12555	6590	3478	1787	1156	687	358	133
16	37650	16692	8762	4612	2344	1517	901	470	175
18	48100	21325	11194	5894	3001	1943	1154	601	223
20	59450	26357	13835	7280	3621	2316	1419	740	276
24	86200	38216	20060	10559	5371	3478	2064	1076	400
28	118050	52336	27472	14464	7370	4772	2834	1480	550
30	135920	60258	31631	16646	8464	5480	3251	1694	631
32	151050	66966	35151	18507	9428	6106	3621	1887	702
36	192080	85156	44700	23541	11991	7747	4598	2400	892

## C<sub>v</sub> Correction for Pulp Stock

Above certain flow velocities the behavior of pulp stock is similar to the water flow and, in these cases, required C<sub>v</sub> can be calculated in the same way.

However, when the differential pressure through the valve is lower than the values indicated in table XIII, the C<sub>v</sub> value initially calculated must be multiplied by the appropriate correction factor.

**PULP STOCK CORRECTION FACTOR (TABLE XIII)**

Valve Size	Pulp Stock Consistency					
	Up to 3%		4%		5%	
8 to 12	2 PSI	0.1 Bar	2 PSI	0.1 Bar	4 PSI	0.3 Bar
14	2 PSI	0.1 Bar	3 PSI	0.2 Bar	6 PSI	0.4 Bar
16	3 PSI	0.2 Bar	9 PSI	0.6 Bar	20 PSI	1.4 Bar
<b>Correction Factor <sup>(1)(2)</sup></b>	1.45		1.65		2.00	

<sup>(1)</sup> For consistencies higher than 5%, contact Valtek Sulamericana. <sup>(2)</sup> For sizes smaller than 6 inches, it is not necessary any correction, independent of the consistency.

# DIMENSIONS, ESTIMATED SHIPPING WEIGHTS

## Pendular Assembly

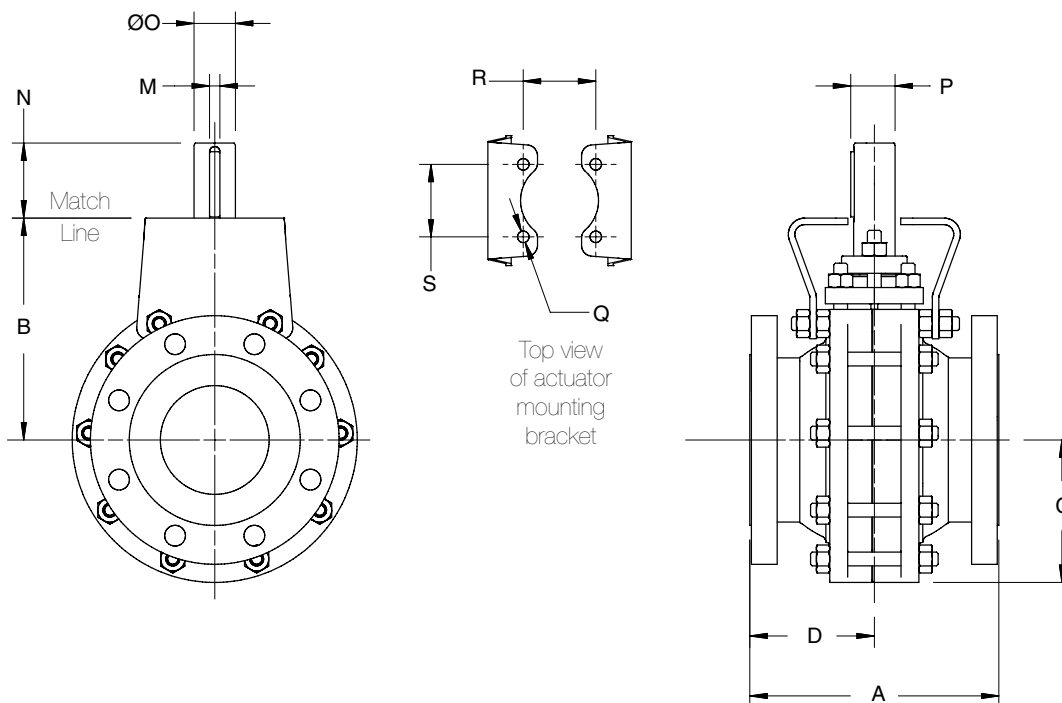

DIMENSIONS <sup>(1)</sup> (TABLE XIV)													
Valve Size (inches)	ANSI Class	A <sup>(2)</sup>	B	C	D	M	N	ØO	P	Q	R	S	Weight
		inches mm											lbs. kg
1	150	6.5	4.41	2.3	3.2	0.187	1.38	0.62	0.710	0.41	3.01	3.01	13
		165	112	58	83	4.76	35	15.83	18.04	10.3	76.3	76.3	6
	300	6.5	4.41	2.3	3.2	0.187	1.38	0.62	0.710	0.41	3.01	3.01	15
		165	112	58	83	4.76	35	15.83	18.04	10.3	76.3	76.3	7
	600	8.5	5.91	3.5	4.3	0.187	1.38	0.62	0.710	0.41	3.01	3.01	31
		216	150	90	108	4.76	35	15.83	18.04	10.3	76.3	76.3	14
1.5	150	7.5	6.02	3.1	3.7	0.250	1.85	1.00	1.133	0.50	3.15	3.15	29
		190	153	80	95	6.35	47	25.37	28.77	12.7	80.0	80.0	13
	300	7.5	6.02	3.1	3.7	0.250	1.85	1.00	1.133	0.50	3.15	3.15	31
		190	153	80	95	6.35	47	25.37	28.77	12.7	80.0	80.0	14
	600	9.5	6.69	3.9	4.7	0.250	1.85	1.00	1.133	0.50	3.15	3.15	66
		241	170	98	121	6.35	47	25.37	28.77	12.7	80.0	80.0	30
2	150	7.0	5.69	3.5	3.5	0.250	2.19	1.00	1.133	0.41	3.01	3.01	35
		178	145	89	89	6.35	56	25.37	28.77	10.3	76.3	76.3	16
	300	8.5	5.69	3.5	4.3	0.250	2.19	1.00	1.133	0.41	3.01	3.01	40
		216	145	89	108	6.35	56	25.37	28.77	10.3	76.3	76.3	18
3	150	8.0	7.05	4.3	4.0	0.375	2.76	1.50	1.601	0.47	3.15	3.15	62
		203	179	110	102	9.52	70	38.07	40.67	11.9	80.0	80.0	28
	300	11.1	7.05	4.3	5.6	0.375	2.76	1.50	1.601	0.47	3.15	3.15	86
		282	179	110	142	9.52	70	38.07	40.67	11.9	80.0	80.0	39
4	150	9.0	8.07	5.2	4.5	0.375	2.68	1.50	1.601	0.50	3.15	3.15	95
		229	205	131	115	9.52	68	38.07	40.67	12.7	80.0	80.0	43

<sup>(1)</sup> For valves operated by means of levers or manual handwheels (equipped or not with gearboxes), consult factory.

<sup>(2)</sup> For sizes 1 and 1.5 inch (CL. 150), the face-to-face dimensions are in accordance with Valtek Sulamericana's standards.

# DIMENSIONS, ESTIMATED SHIPPING WEIGHTS

## Trunnion Assembly

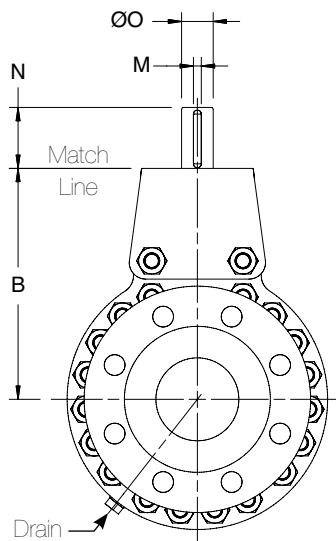

**DIMENSIONS<sup>(1)</sup> (TABLE XV)**

Valve Size (inches)	ANSI Class	A	B	C	D	M	N	ØO	P	Q	R	S	Drain (NPT)	Weight
		inches mm												lbs. kg
2	600	11.5	7.87	4.1	5.7	0.250	1.81	1.00	1.133	0.50	3.15	3.15	1/2"	81
		292	200	103	146	6.35	46	25.37	28.77	12.7	80.0	80.0		37
3	600	14.0	9.76	5.2	7.0	0.375	2.28	1.50	1.601	0.50	3.15	3.15	1/2"	139
		356	248	131	178	9.52	58	38.07	40.67	12.7	80.0	80.0		63
4	300	12.0	8.07	5.2	6.0	0.375	2.68	1.50	1.601	0.50	3.15	3.15	1/2"	139
		305	205	131	153	9.52	68	38.07	40.67	12.7	80.0	80.0		63
	600	17.0	10.87	6.2	8.5	0.375	2.68	1.50	1.601	0.50	3.15	3.15	1/2"	275
		432	276	157	216	9.52	68	38.07	40.67	12.7	80.0	80.0		125
6	150	15.5	11.10	6.9	7.8	0.500	3.66	2.25	2.402	0.50	3.15	3.15	3/4"	198
		394	282	175	197	12.70	93	57.12	61.02	12.7	80.0	80.0		90
	300	15.9	11.50	7.2	7.9	0.500	3.66	2.25	2.402	0.50	3.15	3.15	3/4"	319
		403	292	184	202	12.70	93	57.12	61.02	12.7	80.0	80.0		145
	600	22.0	13.74	8.0	11.0	0.500	3.66	2.25	2.402	0.50	3.15	3.15	3/4"	631
		559	349	202	280	12.70	93	57.12	61.02	12.7	80.0	80.0		287
8	150	18.0	13.15	8.4	9.0	0.500	3.54	2.25	2.402	0.50	3.15	3.15	3/4"	290
		457	334	212.5	229	12.70	90	57.12	61.02	12.7	80.0	80.0		132
	300	19.8	13.58	8.9	9.9	0.750	4.69	2.76	2.949	0.50	3.15	3.15	3/4"	543
		502	345	227	251	19.05	119	70.00	74.90	12.7	80.0	80.0		247
	600	26.0	16.46	11.8	13.0	0.750	4.69	2.76	2.949	0.50	3.15	3.15	3/4"	858
		660	418	299	330	19.05	119	70.00	74.90	12.7	80.0	80.0		390
10	150	21.0	15.41	10.3	10.5	0.875	5.81	3.50	3.693	0.71	6.32	2.76	1"	462
		533	392	262	267	22.22	148	88.90	93.81	18.0	160.5	70.0		210
	300	22.4	15.93	11.0	11.2	0.875	5.81	3.50	3.693	0.71	6.32	2.76	1"	858
		568	405	279	284	22.22	148	88.90	93.81	18.0	160.5	70.0		390
	600	31.0	18.76	12.0	15.5	0.875	5.81	3.50	3.693	0.71	6.32	2.76	1"	1562
		787	477	305	394	22.22	148	88.90	93.81	18.0	160.5	70.0		710
12	150	24.0	18.07	11.7	12.0	0.875	6.22	3.75	3.951	0.71	6.32	2.76	1"	946
		610	459	298	305	22.22	158	95.25	100.35	18.0	160.5	70.0		430
	300	25.5	18.15	12.4	12.8	0.875	6.22	3.75	3.951	0.71	6.32	2.76	1"	1320
		648	461	315	324	22.22	158	95.25	100.35	18.0	160.5	70.0		600
	600	33.0	23.31	14.7	16.5	0.875	6.22	3.75	3.951	0.71	6.32	2.76	1"	2539
		838	592	374	419	22.22	158	95.25	100.35	18.0	160.5	70.0		1154

<sup>(1)</sup> For valves operated by means of levers or manual handwheels (equipped or not with gearboxes), consult factory.

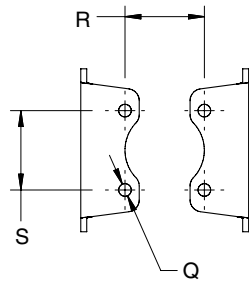

Top view of actuator mounting bracket

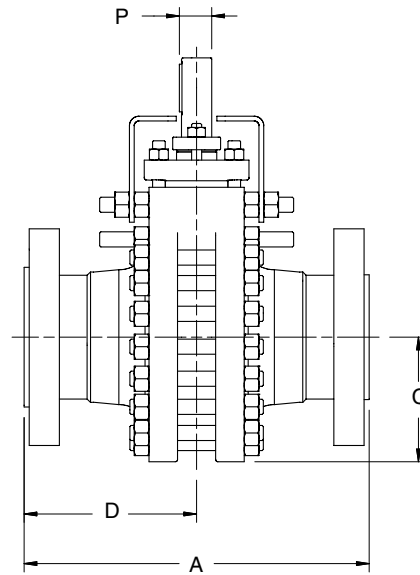

**DIMENSIONS <sup>(2)(3)</sup> (TABLE XV - CONT.)**

Valve Size (inches)	ANSI Class	A	B	C	D	M	N	Ø O	P	Q	R	S	Drain (NPT)	Weight
		inches mm												lbs. kg
14	150	27.0	19.45	13.1	13.5	0.875	6.14	3.75	3.951	0.67	6.32	2.76	1"	1232
		686	494	334	343	22.22	156	95.25	100.35	17.0	160.5	70.0		560
	300	30.0	20.04	13.9	15.0	1.000	7.09	3.75	3.951	0.67	6.32	2.76	1"	1716
		762	509	353	381	25.40	180	95.25	100.35	17.0	160.5	70.0		780
	600	35.0	24.96	16.2	17.5	1.000	7.09	4.13	4.386	0.67	6.32	2.76	1"	3344
		889	634	412	445	25.40	180	105.0	111.40	17.0	160.5	70.0		1520
16	150	30.0	22.01	14.6	15.0	0.875	6.14	3.75	3.951	0.67	6.32	2.76	1"	1606
		762	559	372	381	22.22	156	95.25	100.35	17.0	160.5	70.0		730
	300	33.0	22.72	15.6	16.5	1.250	8.07	3.75	3.951	0.67	6.32	2.76	1"	2332
		838	577	396	419	31.75	205	95.25	100.35	17.0	160.5	70.0		1060
	600	39.0	26.61	18.8	19.5	1.250	8.07	4.72	5.016	0.67	6.32	2.76	1"	5544
		991	676	477	496	31.75	205	120.0	127.40	17.0	160.5	70.0		2520
18	150	34.0	28.90	16.0	17.0	0.875	6.14	3.75	3.951	0.67	6.32	2.76	1"	2882
		864	734	407	432	22.22	156	95.25	100.35	17.0	160.5	70.0		1310
	300	36.0	33.86	17.4	18.0	0.875	6.14	3.75	3.951	0.67	6.32	2.76	1"	3872
		914	860	442	457	22.22	156	95.25	100.35	17.0	160.5	70.0		1760
	600	43.0	36.65	21.5	21.5	1.250	8.86	5.31	5.646	0.67	6.32	2.76	1"	7304
		1092	931	545	546	31.75	225	135.0	143.40	17.0	160.5	70.0		3320
20	150	36.0	30.31	17.8	18.0	1.000	7.09	3.75	4.570	0.67	6.32	2.76	1"	3344
		914	770	452	457	25.40	180	95.25	100.35	17.0	160.5	70.0		1520
	300	39.0	35.20	19.0	19.5	1.000	7.09	3.75	3.951	0.67	6.32	2.76	1"	4334
		991	894	483	496	25.40	180	95.25	100.35	17.0	160.5	70.0		1970
	600	47.0	37.95	23.1	23.5	1.500	9.84	5.91	6.559	0.87	7.48	3.54	1"	8602
		1194	964	588	597	38.10	250	150.0	166.60	22.0	190.0	90.0		3910
24	150	42.0	37.20	21.3	21.0	1.250	8.07	3.75	3.951	0.87	7.48	3.54	1"	5126
		1067	945	542	534	31.75	205	95.25	100.35	22.0	190.0	90.0		2330
	300	45.0	40.98	23.1	22.5	1.250	8.07	4.72	5.268	0.87	7.48	3.54	1"	6886
		1143	1041	586	572	31.75	205	120.0	133.80	22.0	190.0	90.0		3130
	600	55.0	42.72	24.1	27.5	1.500	11.02	6.50	7.157	0.87	7.48	3.54	1"	14388
		1397	1085	612	699	38.10	280	165.0	181.80	22.0	190.0	90.0		6540

<sup>(2)</sup> For manual handwheel operated valves, equipped with gearboxes, consult factory.

<sup>(3)</sup> For larger sizes, consult factory.

Quality Management System



---

**ISO 9001-2000**

Certificate No. 311001 QM

The information and specification contained in this bulletin are considered accurate. However, they are provided only for information purposes and should not be considered as certified. Valtek Sulamericana products are continuously improved and upgraded and the specification, dimensions and information contained herein are subject to change without notice. For further information or to confirm these presented here, contact your Valtek Sulamericana representative. The specific instructions for installation, operation and maintenance of the TBV control valve are provided in Maintenance Bulletin #50.

Viton-A is a registered trademark of Du Pont Dow Elastomers. Inconel is a registered trademark of Special Metals. TBV is a registered trademark of Valtek Sulamericana. Valtek Sulamericana is a registered trademark.

| Printed in Brazil |

**[www.valteksulamericana.com.br](http://www.valteksulamericana.com.br)**

Cat. Valtek Sulamericana TBV - Rev. 0 05/2008E - PN9850002